



Cordella™ Pulmonary Artery Sensor System

Instructions for Use

Rx Only

Exclusively for clinical investigations in Europe.



1415 West Diehl Road
Suite #500W
Naperville, IL 60563
USA
support@endotronix.com
Phone: 1 888 512 5595

EC REP Endotronix Ireland Limited

DCU Alpha Innovation Centre
Old Finglas Road
Glasnevin
Dublin 11, D11 KXN4
Ireland

(page left blank intentionally)

Table of Contents

1. Introduction	5
1.1 Intended Use	5
1.2 Contraindications	5
1.3 Clinical Considerations for Patient Selection	5
2. Device Descriptions	6
2.1 Cordella™ Pulmonary Artery Sensor System	6
2.2 Cordella™ System	9
2.3 Recommended Accessories	10
3. Safety Information	11
3.1 Warnings: Implantation Procedure	11
3.2 Warnings: Reader and Docking Station	12
3.3 Warnings: Calibration Equipment	13
3.4 Precautions	14
3.5 Potential Adverse Events	15
3.6 MRI Safety Information	16
3.7 Sterilization	16
4. Instructions for Use	17
4.1 Pre-Procedure Preparation	17
4.2 Pairing and Interrogating the Cordella Sensor in Packaging	18
4.3 Vessel Mapping and Guidewire Placement	19
4.4 Delivery System Package Inspection	20
4.5 Delivery System & Cordella Sensor Insertion	21
4.6 Cordella Sensor Implantation	22
4.7 Calibrating the Sensor	24
5. Reader Training	26
6. Recalibration	27
6.1 Pre-Procedure Preparation	27
6.2 Recalibration	27
7. Transport	28
8. Peri-Procedural Anticoagulation and Antiplatelet Therapy	28
9. Patient Implant Card	28
10. Audio & Visual Cues	29
11. Maintenance and Storage	30
11.1 Environmental Information	30
11.2 Replacement and Repair	30
12. Inspection & Cleaning Instructions	30
13. Disposal	31
14. Return Materials Authorization (RMA)	31
15. Troubleshooting	31
15.1 Implant Procedure & Delivery System	31
15.2 Pairing and Interrogating the Cordella Sensor	32
15.3 Calibrating the Cordella Sensor	32
15.4 Anomalous PA Pressure Data	33
16. Useful Life	33
17. Clinical Study Information	34
17.1 Introduction	34
17.2 Study Objectives	35
17.3 Study Design	35
17.4 Clinical Inclusion and Exclusion Criteria	36
17.5 Follow-up Schedule	38

17.6 Clinical Endpoints	39
17.6.1 Safety Endpoints	39
17.6.2 Accountability of PMA Cohort	40
17.6.3 Study Population Demographics and Baseline Parameters	42
17.7 Safety and Effectiveness Results	47
17.7.1 Safety Results	47
17.7.2 Effectiveness Results	50
17.7.3 Subgroup Analyses	57
17.7.4 Pediatric Extrapolation	58
17.8 Conclusions	58
17.8.1 Effectiveness Conclusions	58
17.8.2 Safety Conclusions	59
17.8.3 Overall Conclusions	60
18. Contact Us	61
Appendices	62
Appendix A: Electromagnetic Compatibility	62
Appendix B: Equipment Specifications	65
Definition of Symbols	67

1. Introduction

The Cordella Pulmonary Artery Sensor System is intended to measure, record and transmit pulmonary artery pressure (PAP) data from NYHA Class III heart failure patients who are at home on diuretics and guideline-directed medical therapy (GDMT), as well as have been stable for 30 days on GDMT. The device output is meant to aid clinicians in the assessment and management of heart failure, with the goal of reducing heart failure hospitalizations. The Cordella PA Sensor System is not intended for emergency use or real-time monitoring. It is designed to be used with the Cordella™ Heart Failure System (Cordella System) to better connect healthcare professionals and patients with tools for comprehensive heart failure management. The Cordella System consists of the patient-facing myCordella Kit and the clinic-facing myCordella™ Patient Management Portal (PMP).

The Cordella PA Sensor is an implantable blood pressure monitor that permanently resides in the patient's right pulmonary artery. With this Cordella Sensor, PA pressure can be wirelessly measured from the patient's home on demand. Active management of a patient using the Cordella Sensor and the other peripherals of the myCordella Kit may improve long-term outcomes in patients with New York Heart Association (NYHA) Class III heart failure.

1.1 Intended Use

The Cordella Pulmonary Artery Sensor System is intended to measure, record and transmit pulmonary artery pressure (PAP) data from NYHA Class III heart failure patients who are at home on diuretics and guideline-directed medical therapy (GDMT), as well as have been stable for 30 days on GDMT. The device output is meant to aid clinicians in the assessment and management of heart failure, with the goal of reducing heart failure hospitalizations.

1.2 Contraindications

The Cordella Pulmonary Artery Sensor System is contraindicated for patients with an inability to take dual antiplatelet or anticoagulants for one month post implant.

1.3 Clinical Considerations for Patient Selection

The following patients may not be appropriate for implantation of the Cordella PA Sensor System:

- Patients with an active infection
- Patients with a history of recurrent pulmonary embolism (≥ 2 episodes within 5 years) and/or recent deep vein thrombosis (within the past 3 months)
- Patients with known coagulation disorders
- Patients with a hypersensitivity or allergy to platelet aggregation inhibitors including aspirin, clopidogrel, prasugrel, and ticagrelor
- Patients with a known history of life threatening allergy to contrast dye
- Patients unable to tolerate a right heart catheterization
- Patients with a Glomerular Filtration Rate (GFR) < 25 ml/min or who are on chronic renal dialysis
- Patients who have been implanted with a Cardiac Resynchronization Device (CRT)-Pacemaker (CRT-P) or CRT-Defibrillator (CRT-D) within the past 3 months.

2. Device Descriptions

2.1 Cordella™ Pulmonary Artery Sensor System



The Cordella Pulmonary Artery Sensor System is designed for on-demand measurement of pulmonary artery pressure from the patient's home.

The system includes:

- A catheter-based Delivery System with a pre-loaded Cordella Sensor for implant in the pulmonary artery
- Calibration Equipment (CalEQ) for collecting relevant calibration information during implantation
- myCordella Handheld Patient Reader for patient use to measure PA pressure in the home, which communicates wirelessly to the myCordella Tablet
- Cordella Data Analysis Platform (CDAP) for cloud-based storage and analysis of home PA pressure readings (not pictured)

Cordella™ PA Sensor

The Cordella Sensor is a small implant that resides permanently in the patient's right pulmonary artery. The Cordella Sensor does not contain batteries or active electrical components. The Cordella Sensor is not made with natural rubber latex.

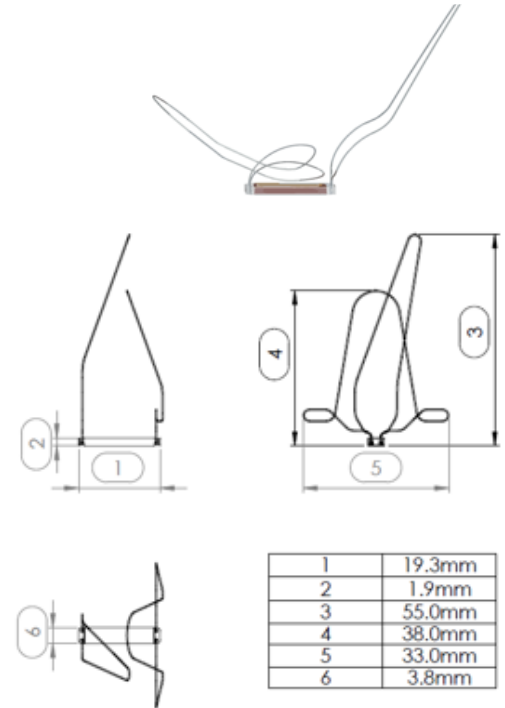

myCordella Handheld Patient Reader

The myCordella Handheld Patient Reader (Reader) is a handheld device that is provided to the patient for at-home use to measure PA pressure on demand. The Reader wirelessly transmits the raw data obtained from the Cordella Sensor to the myCordella Tablet. The raw data is converted into readable data and sent to the myCordella Patient Management Portal for the clinician to review.

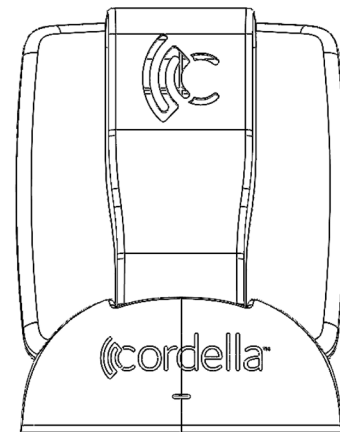

Delivery System

The Delivery System is a catheter with a pre-loaded Cordella Sensor at the distal end and is used to implant the Cordella Sensor into the right pulmonary artery. The Delivery System comprises a stability sheath, torque catheter, handle, torque luer, and side port. Implantation of the Cordella Sensor using the Delivery System is designed to be performed during right heart catheterization through venous access. The Stability Sheath contains a marker band at the distal end to aid in visualization under fluoroscopy. The Delivery System is not made with natural rubber latex.

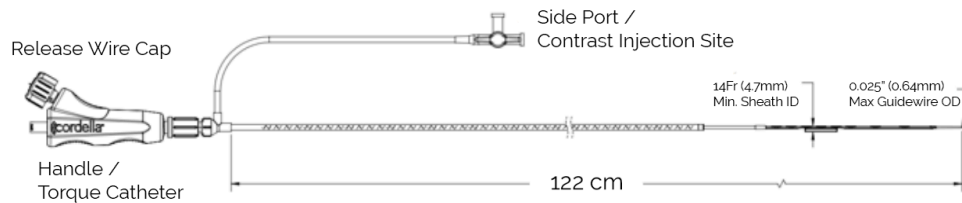

Calibration Equipment

The Calibration Equipment (CalEQ) is hospital equipment that supports the implantation procedure. The main functions of Calibration Equipment include:

- Interrogates the Cordella Sensor to verify proper working condition.
- Facilitates linking of component serial numbers to patient IDs.
- Calibrates the Cordella Sensor to a reference pressure at the time of implantation.
- Trains patient on optimal Reader placement post-procedure.
- Recalibrates the Cordella Sensor to a reference pressure post-implant.
- CalEQ is operated by Endotronix personnel only.

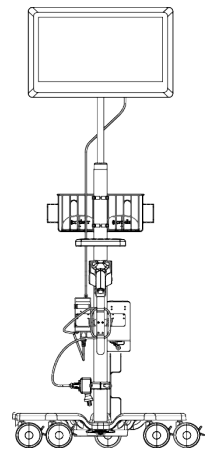

Cordella Data Analysis Platform (CDAP)

The Cordella Data Analysis Platform (CDAP) is a secure, cloud-based, standalone application that collects and stores raw Reader data and processes it according to pre-defined algorithms to convert it into final-form pulmonary artery pressure data.

2.2 Cordella™ System

myCordella™ Patient Management Portal (PMP)

A web-based application that displays patient data received from the myCordella Tablet to the clinician. The PMP is intended to assist clinicians in managing patients.



myCordella™ Tablet

An intuitive, user-friendly display screen that assists patients with obtaining vital sign measurements.

- Collects & securely transmits daily health information to clinicians
- Facilitates review of past measurements
- Allows secure communication between patient and clinician



myCordella™ Patient Kit*

- myCordella Tablet
- Weight Scale
- Blood Pressure Monitor
- Pulse Oximeter
- myCordella Tablet Stand
- myCordella Carrying Case
- Stylus
- myCordella Patient Manual
- myCordella Quick Start Guide

*The set of components may be labeled as a system pack; however in this document it will be referred to as a patient kit.



2.3 Recommended Accessories

Cordella Pulmonary Artery Sensor System is recommended for use with the accessories listed in the following table. These accessories are not included in the Cordella Sensor and Delivery System packaging.

Item	Specifications
14F Introducer Sheath	Cook performer introducer, Item No. G08024 RCF 14.0-38J-14F - 13cm length
PA Catheter	Pulmonary artery catheter
Procedural Guidewire (for inserting the Delivery System)	Cook Extra Stiff Amplatz Guidewire, Hi-Torque Steelcore 18, Hi-Torque Steelcore 18LT, (260-300 cm; straight-tip; 0.025" or 0.018")
Guidewire for troubleshooting PA position, if necessary	Optional guidewire per operator's preference. Wires that are steerable or have a shaped or shapeable tip may facilitate gaining distal vessel access.
Guide Catheter	Guide catheter with marker bands per operator's preference compatible with power injection systems

Additionally, the following catheter lab equipment and supplies are required during Cordella Sensor implantation. They are the same items typically used during right heart catheterization procedures.

- Fluoroscope with digital angiography capabilities and ability to record and recall images
- Fluid-filled or electrical blood pressure monitoring equipment to obtain PA pressure measurement during right heart catheterization
- Hand injector and radiopaque contrast media for visualization.
- Power injector for angiograms
- Patient Monitor
- Hemodynamic module

3. Safety Information

Before use of the Cordella Pulmonary Artery Sensor System, thoroughly read and understand the instructions for use to avoid potential injury or death.

 Warnings	<p>Warnings indicate the potential for serious adverse reactions or safety hazards, and limitations in use imposed by them.</p>
Precautions	<p>Precautions indicate special care that should be taken to ensure safe and effective use of the device.</p>



3.1 Warnings: Implantation Procedure

- Only trained personnel should use the Cordella Pulmonary Artery Sensor System.
- The implant procedure must be performed by trained clinical personnel with the appropriate interventional and endovascular skills, including but not limited to implantable device placement and deployment over a guidewire and in a location with the infrastructure to support right heart catheterizations.
- DO NOT reuse, reprocess, or re-sterilize the Cordella Sensor and Delivery System. The Cordella Sensor and Delivery System are for single use only. Any reuse, reprocessing, or re-sterilization may influence the structural integrity of the components of the device and could lead to transmission of infectious diseases, other types of infections from one patient to another, as well as many other serious adverse events including but not limited to injury, illness, or death of the patient.
- Use only the cables and accessories provided. The use of accessories, transducers, or cables other than those specified, with the exception of transducers and cables provided as replacement parts, may result in increased emissions, decreased immunity of the system, inaccurate readings, damage to the system, injury to user, or improper operation.
- Fluoroscopy is required to perform the implant procedure in order to visualize the target vasculature and to ensure proper device placement.
- The operator should be cautious not to dislodge or damage previously implanted medical devices including pacemaker and/or implanted cardiac defibrillator leads.
- Cordella Sensor should be placed into the patient's right pulmonary artery with diameter ≥ 12 mm and ≤ 26 mm at the right pulmonary artery downturn. Sensor placement in < 12 mm vessel may result in vessel injury and Sensor placement in > 26 mm vessel or Sensor placement outside of the right pulmonary artery downturn may result in Sensor instability.
- As much as possible, avoid contacting the Cordella Sensor with any subsequent catheters or wires. When contact is unavoidable (e.g. during Delivery System withdrawal), take care to avoid disrupting the Cordella Sensor.
- Excessively forceful movements of the Delivery System may result in vessel injury or perforation. DO NOT advance Delivery System if excessive resistance is felt.
- DO NOT advance or retract the Delivery System without a guidewire in place.
- Following device implantation, all future right heart catheterizations (RHCs) will require fluoroscopy to reduce the likelihood of catheter or guidewire contact with the Cordella Sensor. Future RHC should be done via left pulmonary artery.
- DO NOT pull the release wires prior to intended deployment. Any strain on the release wires may loosen the Cordella Sensor tie down mechanism.
- DO NOT mishandle the Delivery System or use it if the packaging or any components are not sterile, have been opened or are damaged (i.e. kinked or stretched), or the expiration date has elapsed. DO NOT attempt to repair a damaged Delivery System. Replace it with another Delivery System from inventory and return the device to Endotronix through the RMA process (see Section 14).



3.1 Warnings: Implantation Procedure (Cont.)

- DO NOT attempt to modify, disassemble, or otherwise alter the Cordella Pulmonary Artery Sensor System.
- A continuous heparin drip should be used to prevent clotting. The ACT should be at least 200 sec from the time of Delivery System insertion until the Stability Sheath is removed.
- DO NOT expose the Cordella Sensor to therapeutic levels of ultrasonic energy.
- After the procedure, it is critical for the patient to adhere to prescribed anticoagulation, antiplatelet, and other medications from the physician.
- DO NOT use an automated power injector through the Stability Sheath.
- DO NOT insert the Cordella Sensor by pushing the Delivery System without supporting the Cordella Sensor from behind as this may result in damage to the device.
- If gripping the Cordella Sensor is necessary, grab only by the sides and not the top surface as this may cause Sensor damage.



3.2 Warnings: Reader and Docking Station

- The Reader is suitable for home healthcare environments and professional healthcare facilities except near active heart failure hospital equipment and the radiofrequency (RF) shielded room of a medical electrical (ME) system for magnetic resonance imaging, where the intensity of electromagnetic (EM) disturbance is high.
- The Reader and Docking Station should not be used adjacent to or stacked with other equipment. If it is necessary to operate the components adjacent to or stacked with other equipment, verify that the system is operating normally in the configuration in which it will be used.
- DO NOT expose any power accessories, the Reader, or the Docking Station to food or liquids.
- DO NOT use myCordella in the presence of explosive or flammable anesthetic agents.
- Power cables may pose a tripping hazard. Be mindful of cords crossing walkways.
- DO NOT position power cables in any manner that may cause entanglement or strangulation.
- Other equipment generating electromagnetic fields may interfere with the Reader. When possible, avoid using the Reader while simultaneously using other equipment such as: patient monitoring systems, chest ECG leads, motors on motorized beds, pagers, RFID tags, laptop computers, tablets, cell phones, cordless phones, wireless routers, continuous glucose monitors on the right arm, air conditioners within -5 feet (1.5m), UHF RFID tags within -2 feet (0.6m), and RFID equipment operating at 2.45 GHz within -4 feet (1.2m).
- The Reader requires special precautions regarding electromagnetic compatibility (EMC) and needs to be placed into service according to the EMC information provided. If interference is noted while taking a reading (e.g. if CalEQ and Reader continue to disconnect), remove or stop using the interfering equipment.
- Portable RF communications equipment (including peripherals such as antenna cables and external antennas) should be used no closer than -5 feet (1.5 m) from any part of the Reader. Otherwise, degradation of the performance of the Reader could result.
- The patient should not have necklaces, jewelry, shirt pocket contents, metal objects, and near field communication objects in the vicinity of the reading location while taking a reading.
- If the skin becomes red, warm, or irritated, immediately stop using the Reader and contact Customer Service.



3.2 Warnings: Reader and Docking Station (Cont.)

- DO NOT use more than one Reader in the same general vicinity at one time, as use of multiple Readers at once may cause them to interfere with each other.
- To ensure accuracy, the Sensor must be recalibrated approximately every three years using a RHC procedure.



3.3 Warnings: Calibration Equipment

- CalEQ must be operated by trained Endotronix personnel only.
- The CalEQ is suitable for professional healthcare facilities except for near active heart failure hospital equipment and the radiofrequency (RF) shielded room of a medical electrical (ME) system for magnetic resonance imaging, where the intensity of electromagnetic (EMI) disturbance is high.
- The CalEQ should not be used adjacent to or stacked with other equipment. If it is necessary to operate the components adjacent to or stacked with other equipment, verify that the system is operating normally in the configuration in which it will be used.
- Portable RF communications equipment (including components such as antenna cables and external antennas) should be used no closer than ~5 feet (1.5m) from any part of the CalEQ. Otherwise, degradation of the performance of the CalEQ could result.
- Only use CalEQ accessories, cables, and/or components that have been supplied by Endotronix. Using other unlabeled accessories, cables, and/or components may affect patient safety and measurement accuracy.
- The CalEQ should not be used to obtain pulmonary artery pressure and/or pulmonary artery pressure derived parameters for diagnostic purposes.
- Only connect CalEQ to 60601-1 compliant patient monitors. Using non-compliant patient monitors may affect patient safety and measurement accuracy.
- To avoid risk of electric shock, the CalEQ must only be connected to a supply main with protective earth.
- DO NOT plug additional devices into the CalEQ power strip.

3.4 Precautions

- Only use the side-port of the Stability Sheath for injection and aspiration. The guidewire lumen should not be used for aspiration or injection after initial flushing.
- The implant procedure is an adjunct to a standard (RHC) procedure. All standard protocols for the RHC should be followed.
- Explanting the Cordella Sensor after implantation is not recommended.
- If there is evidence of a change in device performance, please contact Customer Service.
- The Cordella Sensor and Delivery System are only compatible with a 14 French introducer or larger. Use of a smaller introducer may damage the Cordella Sensor or Delivery System product and may prevent introduction. The use of peel away introducers is not recommended.
- Torquing the Stability Sheath with the Torque Catheter removed may result in kinking of the Stability Sheath and may impact the reliability of a fluid-filled pressure measurement.
- Precaution should be taken to avoid damage to the Cordella Sensor prior to implantation. It is an all-glass enclosure and it is fragile. Only remove from packaging when ready to start a procedure. Take care to avoid shock or drop to the distal end of the Delivery System where the Cordella Sensor is pre-mounted. Care should be taken to limit contact with the Cordella Sensor prior to insertion through the introducer sheath.
- Avoid squeezing or pinching the body of the Cordella Sensor if at all possible.
- DO NOT place more than one Cordella Sensor in a patient. The two Cordella Sensors may interfere with each other and limit the ability to obtain accurate readings.
- Activities that may expose the patient to ambient pressure extremes may affect device performance. If the patient plans to SCUBA dive, please contact Customer Service.
- Accuracy of the Cordella Pulmonary Artery Sensor System is slightly affected by large changes in elevation between the initial baseline calibration and subsequent measurements. Readings may lose accuracy when taken at >2000m of elevation. If a patient plans to travel or move to a location at >2000m of elevation, contact Customer Service.
- The CalEQ should not be used in the sterile field.
- DO NOT expose any components of myCordella to water or liquids. Contact Customer Service for a replacement if any components are exposed to liquids.
- DO NOT drop the Reader. Handle with care.
- If dropped, the Reader battery may be exposed. If the battery is exposed, contact Endotronix immediately for a replacement Reader. Any damage to the Reader may result in an inaccurate reading.
- DO NOT use the Reader if the plastic casing has been damaged or any component becomes dislodged.
- If the Reader label becomes compromised, contact Endotronix Customer Service
- CalEQ and the Reader contain a Lithium-ion battery.
- LVAD and Continuous Glucose Monitor compatibility with the Cordella System has not been assessed.
- Improper or rapid removal of the Delivery System may cause vessel damage.

3.5 Potential Adverse Events

Potential risks associated with the overall procedure include potential access complications associated with standard right heart catheterization, the potential risks of conscious sedation, and the use of angiography:

- Allergic reaction
- Arrhythmias
- Bleeding complications (which may require transfusion)
- Cardiac arrest
- Chest pain
- Death
- Device embolization/migration
- Device explant
- Emergent or urgent cardiac, vascular, and/or other surgery necessitated by the device or implant procedure (e.g., coronary sinus lead revision)
- Endocarditis or device infection
- Entry site complications (e.g., hematoma, dissection)
- Fracture of a component of the device/system that may or may not lead to serious injury or surgical intervention.
- Gastrointestinal bleed
- Hemoptysis
- Hypo or hypertension
- Infection or fever
- Lead dislodgement
- Peripheral embolism/thrombus
- Pulmonary embolism/pulmonary occlusion
- Pseudoaneurysm of the vein
- Radiation exposure
- Reaction to contrast media/medication
- Renal insufficiency or failure
- Respiratory distress or failure (breathing problems)
- Right atrial/ventricular and coronary sinus lead dislodgement
- Sepsis
- Valvular injury (tricuspid and/or pulmonary)
- Vascular complications (e.g., venous dissection, perforation, rupture, arteriovenous fistula.)
- Vessel trauma which may require surgical repair
- Worsening heart failure

3.6 MRI Safety Information

MRI simulations and non-clinical testing determined that the Cordella Pulmonary Artery Pressure Sensor is MR Conditional. A patient with the Cordella Pulmonary Artery Pressure Sensor may be safely scanned under the following conditions. Failure to follow these conditions may result in injury to the patient.

 MR Conditional	
Parameter	Condition of Use/Information
Nominal Values of Static Magnetic Field (T)	1.5-Tesla or 3.0-Tesla
Static Magnetic Field Orientation	Horizontal
Maximum Spatial Field Gradient (T/m and gauss/cm)	40-T/m (4000-gauss/cm)
Type of RF Excitation	Circularly Polarized (CP) (i.e., Quadrature-Transmission)
Transmit RF Coil Information	There are no transmit RF coil restrictions
Receive RF Coil Information	There are no receive RF coil restrictions
Operating Mode of MR System	Normal Operating Mode
Maximum Whole Body Averaged SAR (W/kg)	2-W/kg (Normal Operating Mode)
Limits on Scan Duration	Whole body averaged SAR of 2-W/kg for 30 minutes of continuous RF exposure with a 5 min. cool down period before the next session
MR Image Artifact	The presence of this implant produces an imaging artifact. Therefore, carefully select pulse sequence parameters if the implant is located in the area of interest.

Under the scan conditions defined, the Cordella Sensor is expected to produce a maximum temperature rise of 5°C after 15 minutes of continuous scanning. If defined MRI conditions are not followed, there is increased risk of additional heating or movement of the Cordella Sensor or of damage to the Cordella Sensor.

Selecting the optimal MR imaging parameters may be necessary if the goal is to image close to the Cordella Sensor. In non-clinical testing, the image artefact caused by the Cordella Sensor extends approximately 6 mm from this device when imaged with a gradient echo pulse sequence and a 3 Tesla MR system.

NOTE: It is important that the patient understands they should inform clinical staff who will be performing an MRI scan that the patient has an implanted Cordella Sensor and to refer to these guidelines. The MR Conditional symbol is on the patient's implant card, which should be given to the patient after the implant and be carried with them at all times. The Cordella Sensor is safe to use with ultrasound imaging, but DO NOT expose to therapeutic levels of ultrasonic energy.

Contact Customer Service for current MR Conditional labeling and the most up-to-date instructions for this device in the MR environment.

3.7 Sterilization

The Delivery System package contents have been sterilized with ethylene oxide before shipment. The system is for single use and is not intended to be re-sterilized. If the sterile package has been compromised or the expiration date has been reached, replace it with another Delivery System from inventory and contact Customer Service.

4. Instructions for Use

Implanting physicians are required to have completed the Cordella Pulmonary Artery Sensor System training, which includes didactic and clinical education material. CalEQ must be operated by trained Endotronix personnel.

Figures in this manual are intended for reference only and may not be an exact replication of the screens as a result of continuous software improvements.

4.1 Pre-Procedure Preparation

1. Within the myCordella Patient Management Portal on a separate computer, download and print the patient's QR Barcode Report through the Download Wizard in the patient's chart (for detailed instructions, see the myCordella Patient Management Portal Clinician Manual: PA Pressure).
2. Before the procedure, transport the CalEQ and Delivery System unit box, including a backup Delivery System, to the catheterization lab (see Section 7 Transport). Ensure the CalEQ includes the Interconnect Cable (if applicable). Unpack and fully charge two Readers and place them on the CalEQ Docking Stations. If possible, keep CalEQ plugged in for the duration of the procedure. If you will be operating CalEQ using battery power, ensure that the CalEQ and Readers are fully charged and turned off before the start of procedures for the day (i.e. the Docking Station LED should be solid white). See Section 10 Reader Audio & Visual Cues.
3. Plug in the CalEQ power strip to an easily accessible outlet. Ensure the Readers are in the Docking Stations and the Docking Stations are plugged into the power strip. Always keep Readers docked when not in use. The light on the Docking Station will blink while charging and change to solid when the Reader is fully charged. To turn a Reader on, press and hold the power button for several seconds. **DO NOT** use excessive force when pressing the power button to avoid potential damage to the device.
4. Turn on the CalEQ by pressing the power button on the bottom of the monitor and sign in as the CalEQ user.

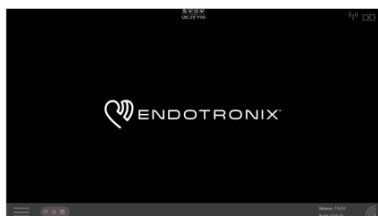

5. To calculate reference pressure parameters necessary for calibration, the CalEQ may use hemodynamic data obtained from the analog output of the hospital's hemodynamic module. Follow the steps below to confirm proper set-up with the monitor. If an Interconnect Cable is not provided with CalEQ, calibration will be based on manually entered reference pressure values rather than hemodynamic data fed from the monitor.
 - The cable input is located on the rear of the stand. The Interconnect Cable's BNC connector should remain attached to the cable input on the CalEQ. Connect the other end of the Interconnect Cable to the hemodynamic module's analog output. This will provide a pulmonary artery pressure measure to the CalEQ for calibration measurements. For compatible Interconnect Cables, see the Calibration Equipment Operator's Manual.
 - The analog invasive blood pressure signal from the hemodynamic module must be configured to the industry standard of 1V/100mmHg and 0V=0mmHg to be compatible with the CalEQ. For more information on configuring the hemodynamic module, contact Customer Service or review the operating instructions provided by the manufacturer of the patient monitor.
 - The CalEQ is installed and configured by Endotronix based on the hemodynamic module to be used. Please notify Customer Service if there is a change in hemodynamic module as it may impact the compatibility and accuracy of the reference pressure signal obtained by CalEQ.

4.2 Pairing and Interrogating the Cordella Sensor in Packaging

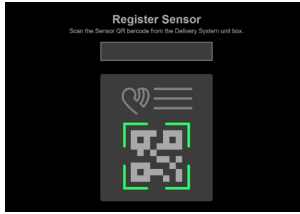

1. Press 'Calibrate.' Scan the QR code on the Delivery System unit box.

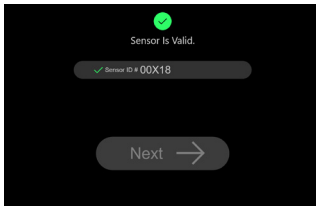

2. On the confirmation screen, ensure there is a green checkmark on the screen. Press the "Next" button if the information matches.

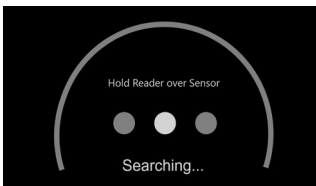

3. Undock the Reader when prompted. While searching for the Sensor, the Reader will display a solid blue light and will beep twice every few seconds.



4. Position the Reader along the top of the Delivery System box near the location symbol shown here. Until a signal is found, reposition the Reader over the top and side of the box.
Left PA

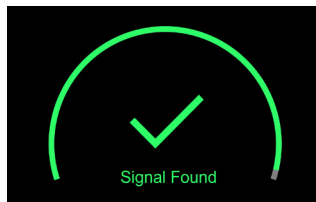

5. The CalEQ will search for a signal from the Sensor. If a signal cannot be found, DO NOT use the Delivery System. Repeat the procedure in Section 4.2 starting at step 1 with a new Delivery System package and contact Customer Service after the procedure.

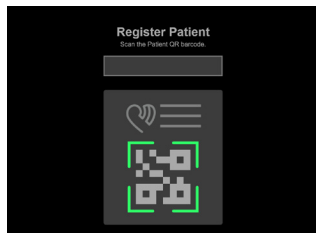

6. When prompted to pair to the patient, scan the QR Barcode Report that was printed from the PMP. If the patient ID does not match, the PMP barcode report will need to be reprinted and rescanned.

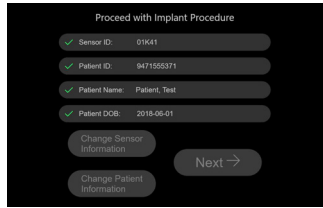

7. On the confirmation screen, ensure all Cordella Sensor and patient information is correct.

DO NOT scan visibly damaged barcodes; use a different Delivery System.

4.3 Vessel Mapping and Guidewire Placement

The Cordella Sensor is implanted in the patient's right pulmonary artery. The following image is provided for reference with useful anatomical landmarks indicated:

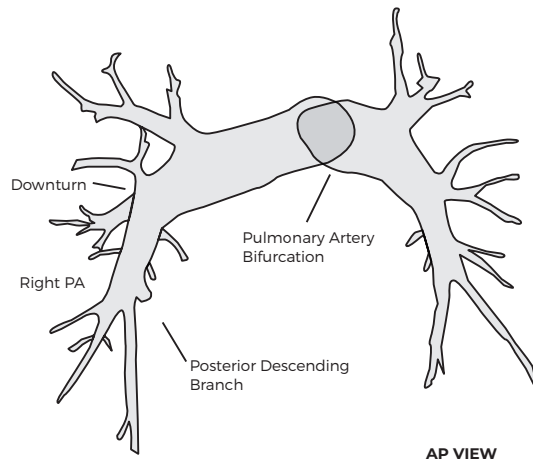

1. Set up the patient for venous access (femoral or right internal jugular) per standard protocol. Position ECG leads as far away from the right side of the patient's chest and side as possible. The use of limb ECG leads is recommended.
2. Gain access to the patient's vein and dilate to allow for a 14 French introducer. Perform a right heart catheterization.
3. Ensure the field of view of the right lung is centered and perform right pulmonary artery angiography in AP view and LAO-CAU 30/30 views. Use either power-injection with angiography catheters (such as pigtail or straight flush) or hand-injection with a PA catheter (or any other preferred catheters). The physician is responsible for selecting the type, amount, and concentration of contrast agent as well as the angiography settings and dose of ionizing radiation. Make sure the images visualize the RPA downturn and the posterior descending branch.
4. Assess RPA anatomy using the obtained images:

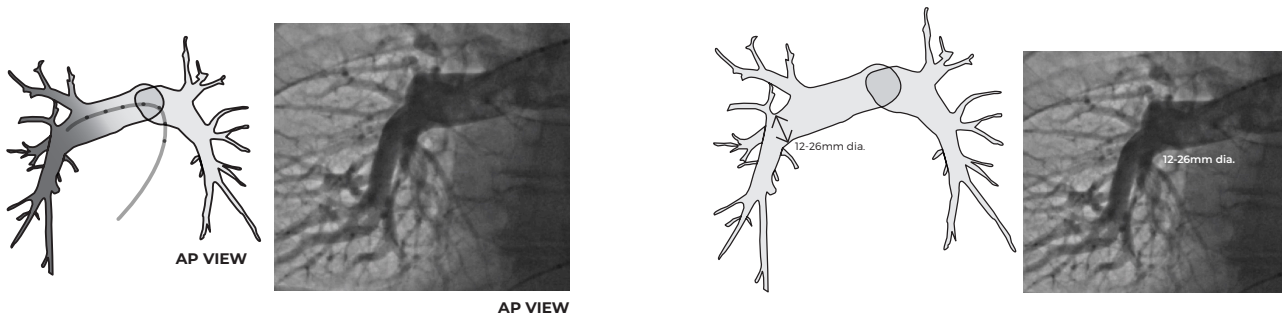

- A. Use AP view to detect and measure the diameter of the downturn of the RPA (target location for the sensor). The vessel at this location must be between 12-26 mm. Quantitative Vascular Analysis (QVA) should be used if the vessel size is indeterminate. If the vessel appears to be either larger or smaller than the indicated range, abort the procedure and DO NOT implant the Cordella Sensor.
 - B. Use LAO-CAU view to visualize, detect and confirm the distal pathway of the posterior descending branch for the guidewire and the delivery system.
5. Introduce a guidewire (.018"- .025", 260cm-300cm) through the lumen of the catheter extending into the descending posterior branch of the right pulmonary artery. Ensure that the wire follows the following path:
- In the AP view: Largest descending posterior vessel.
 - In the LAO/CAU (30/30) view: Largest descending posterior vessel.
- The wire should remain in this branch for 6 cm beyond the downturn.

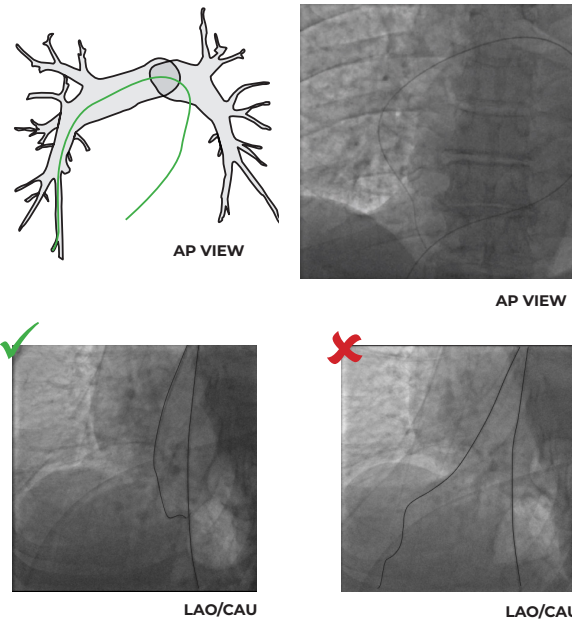

6. Remove the catheter, leaving the guidewire in place.



WARNING: Ensure that the guidewire is in the right pulmonary artery distal to the implant location and NOT in a side branch. Correct guidewire position should be confirmed in BOTH the AP and LAO/CAU 30/30 views.

4.4 Delivery System Package Inspection

Inspect the Delivery System package carefully for any rips, tears, or other damage before opening. If the integrity of the sterile package has been compromised, or the product or package is defective, DO NOT use the product and contact Customer Service to initiate a Return Material Authorization (RMA) procedure.

The unit box contains one Cordella Sensor tied down to the distal end of the Delivery System and the product documentation.

4.5 Delivery System & Cordella Sensor Insertion

1. Remove the Delivery System from the sterile packaging and record the Sensor Serial Number in the patient's chart with the peel and stick label.
2. Inspect the entire effective length of the Delivery System carefully for any damage, including kinks, burrs, roughness, loose connections, handle rotation ability, and a correctly tied-down Sensor. The features of the Delivery System handle are labeled below:

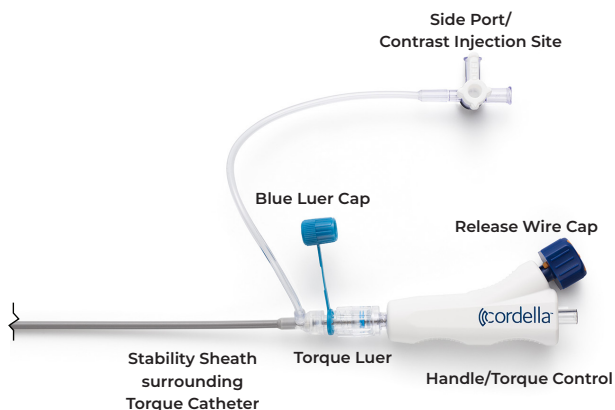

3. The following image displays the tied-down Sensor, for reference.



4. If the Delivery System or Cordella Sensor appears damaged or defective, DO NOT use the product and contact Customer Service to initiate an RMA procedure.



WARNING: The Cordella Sensor should not be interrogated by the Reader after removal from the packaging until the Sensor is implanted.

5. Remove the stylet from the distal end of the Delivery System and flush the side port and guidewire lumen with sterile saline.
6. Thread the Delivery System over the guidewire through the distal tip (front-end loading).

- Grip the catheter directly behind the Cordella Sensor making contact and supporting the back end of the Sensor as shown, and gently push the Sensor through the introducer. Care should be taken to push from the back of the Cordella Sensor to minimize damage and changes to the tiedown configuration.

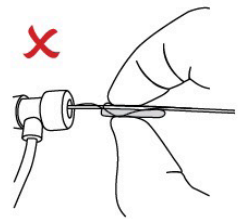
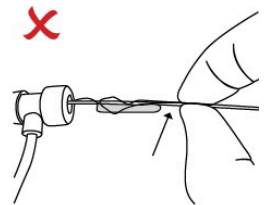
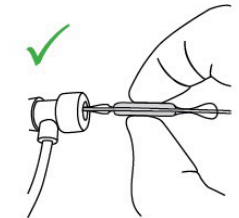
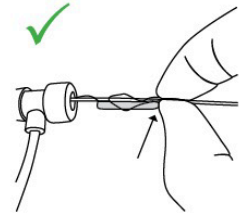

WARNING: DO NOT insert the Cordella Sensor by pushing the Delivery System without supporting the Cordella Sensor from behind as this may result in damage to the device.

WARNING: If gripping the Cordella Sensor is necessary, grab only by the sides and not the top surface as this may cause Sensor damage.

- Slowly push the Cordella Sensor through the introducer. If severe resistance is encountered, stop pushing the Cordella Sensor and attempt to identify the source of resistance. Proceed cautiously.
- Once inserted, the delivery system should be gently advanced using fluoroscopic guidance over a guidewire. If resistance is encountered (i.e. at heart valves or other anatomical structures), the delivery system should be rotated and/or pulled-back before being advanced further.

4.6 Cordella Sensor Implantation

- The target location for the Cordella Sensor is at the downturn of the right PA (highlighted in the figure below for a representative typical PA anatomy). The location can be defined by the overlapping region of the right PA trunk and the downturn as illustrated below. The distal radiopaque marker bands on the Sensor should be within the highlighted area upon Sensor deployment. Anterior-Posterior imaging is required for proper anatomical visualization.

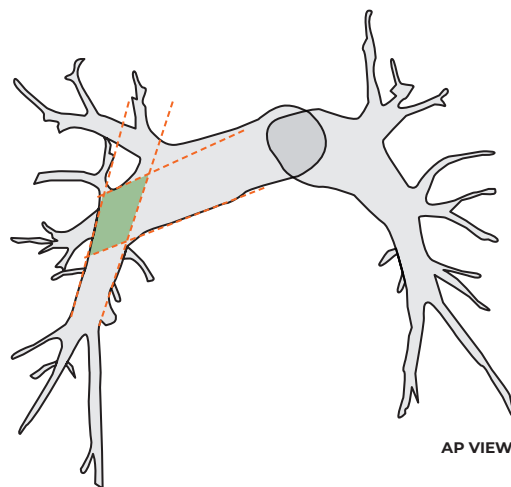

-
- Advance the Cordella Sensor to the target area by gripping the handle and navigating through the heart to the right pulmonary artery.



- The Cordella Sensor has three (3) radiopaque marker bands to help identify rotational position of the Sensor. Once in the optimal position, rotate the Cordella Sensor using the handle as necessary to ensure the Sensor is anterior facing as shown below:

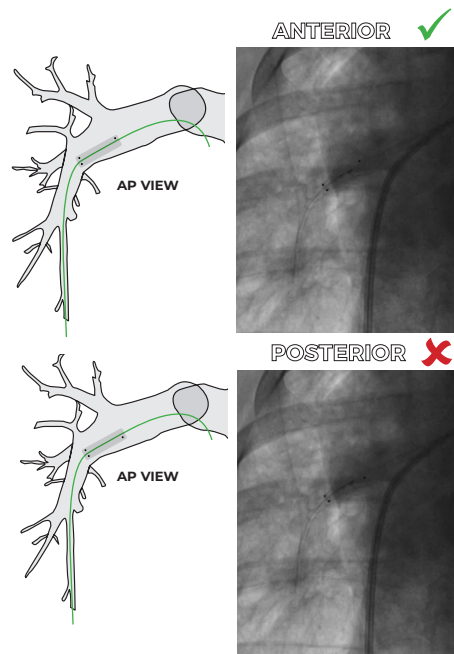

- Once in target deployment position (distal end of Sensor body at RPA downturn, anterior facing), while stabilizing the handle, deploy the Cordella Sensor by rotating the release cap a quarter turn counterclockwise and slowly pulling the release wire cap parallel to the Delivery System, then fully removing the release wires. Release wire cap and wires should be discarded.



- Once the Cordella Sensor is deployed, under fluoroscopic guidance, retract the guidewire into the Torque Catheter and gently withdraw the Delivery System and guidewire together approximately 2 cm away from the deployed Sensor. Assure that the Torque Catheter is not engaging with the Sensor. If this occurs, stop retraction immediately and rotate Torque Catheter before reattempting withdrawal of the sheath and catheter.

- Unscrew the torque luer to disconnect. Hold the handle in a stable position within the palm of the hand.

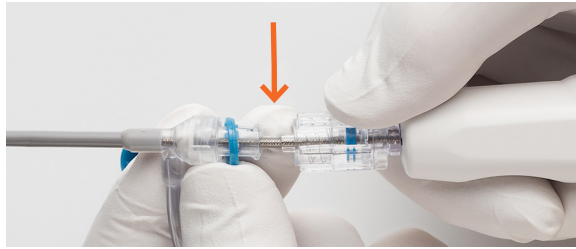

- While visualizing under fluoroscopy, gently and slowly withdraw the Torque Catheter past the Cordella Sensor, making sure not to disturb the Cordella Sensor location. Leave the Stability Sheath in place proximal to the newly deployed Cordella Sensor. Ensure that the Stability Sheath is not engaging with the Sensor.



WARNING: If the Torque Catheter engages the Cordella Sensor, stop withdrawing the Torque Catheter, rotate approximately 90 degrees and resume slow, gentle retraction until clear of the Cordella Sensor.

- Screw the tethered blue luer cap onto the Stability Sheath hub to prevent back-bleeding through the hemostasis valve.
- Use the Stability Sheath as a fluid-filled column to obtain a reference pressure by attaching the side port to the pressure transducer, making sure to:
 - Adjust the pressure transducer height to mid-axillary height
 - Flush the catheter and fluid line to ensure there are no air bubbles
 - Zero the measurement
 - Check that the catheter tip is positioned within the PA and that the catheter does not cross the Sensor.



WARNING: Avoid torquing the Stability Sheath when used as a fluid-filled column. Torquing can result in kinks which inhibit accurate reference pressure measurements for Sensor calibration.

4.7 Calibrating the Sensor

NOTE: During Reader operation, electromagnetic interference (EMI) generating equipment may need to be temporarily moved away from the Reader's zone of operation. This may include temporarily repositioning other medical equipment such as any ECG leads, or patient monitoring systems, as well as other non-medical equipment such as pagers away from the Reader.



WARNING: DO NOT USE the Reader near radio transmitters such as Walkie Talkies or intercom systems.

- With the catheter placed and the Interconnect Cable connected to the patient monitor, the CalEQ will immediately display the fluid-filled reference pressure signal. Skip this step if the CalEQ is not set up to accept hemodynamic data fed from the hemodynamic module. Compare the fluid-filled reference pressure signal on CalEQ with that on the hemodynamic module. Press "Continue" button if signal is correctly displayed.

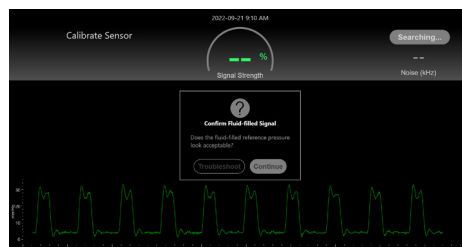

2. Undock the Reader when prompted. CalEQ will show the live, uncalibrated waveform of the Cordella Sensor. Adjust the position of the Reader over the patient's chest until the signal strength percentage is as high as possible (>80%). Ensure the noise level is minimized by following the guidance and warnings regarding EMI. Once optimal signal percentage is achieved (>80%), hold the Reader still for 20 seconds and monitor the waveform until calibration automatically begins.



3. CalEQ will calibrate the Cordella Sensor for 18 seconds. DO NOT adjust the Reader position or patient monitor connections during this time. A progress bar displays the progress through calibration, and the live waveforms will be paused.



4. When prompted, dock the Reader.
5. If reference pressures will be manually entered, the CalEQ system will prompt the user to zero the reference pressure. Enter the systolic and diastolic values from the fluid-filled pressure measurements on the patient monitor. Press the "Next" button.
6. A report containing Cordella Sensor pressures, reference pressures, a comparison between them, and the corrected waveform will appear. If the results are acceptable, press the "Accept" button. If a recalibration seems necessary for any reason, press the "Calibrate Again" button and repeat the calibration steps.



7. After the procedure, save the calibration data. If the CalEQ is connected to the network, select the "Upload to Cloud" button and wait for verification that the upload was successful. If the CalEQ is not connected to the network or otherwise cannot upload, press "Upload Later." See Section 15.3 for instructions how to upload the calibration data once connection to the network is restored.

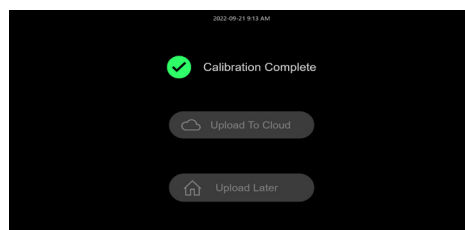

8. Remove the Stability Sheath. Close the venous access site per standard protocols.

5. Reader Training

Post-implant, patients should complete training to learn the best placement of the Reader. This training may be completed using CalEQ or the myCordella Tablet.

To initiate training using CalEQ, follow these steps:

1. From the CalEQ home screen, the user can press the "Training" button.

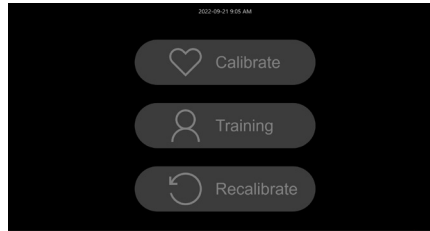

To initiate training using the myCordella Tablet, follow these steps:

1. Pair the Reader that was used for calibration to the patient in PMP. See myCordella Patient Management Portal Clinician Manual: PA Pressure for instructions.
2. Press "Refresh" on the patient's Tablet. The Reader will then be paired with the Tablet.
3. Choose the "Take Test" button and select "PA Pressure" on the Tablet.

As the patient moves the Reader around on their chest and side, the display will provide feedback on the signal strength. As signal strength changes, the pointer on the dial will move clockwise or counterclockwise and the signal symbol below will grow and shrink between one and three signal bars. The patient should be trained to consistently place the Reader in the position that maximizes the signal strength without entering the red section that indicates the Reader is too close.

When using the Tablet, a reading will begin once the Reader has reached its signal strength threshold.

When using the CalEQ, there is no limit to the number of times a patient can practice locating the optimal Reader position, as the Reader will not start taking a reading even when it has reached its signal strength threshold.



NOTE: The Reader must be disconnected from the CalEQ before it can be used with the patient's Tablet. Follow prompts on CalEQ to disconnect the Reader.

6. Recalibration

Post-implant, the Sensor may need to be recalibrated if there is anomalous PA pressure data and Endotronix Customer Service has recommended a recalibration. See Troubleshooting Section 15.4 for more information. Additionally, to ensure accuracy, the Sensor must be recalibrated approximately every three years. Recalibration is completed during a RHC procedure.

6.1 Pre-Procedure Preparation

Complete the Pre-Procedure Preparation steps from Section 4.1. Contact Customer Service to obtain the Sensor QR Barcode and print.

6.2 Recalibration

1. On the CalEQ, press "Recalibrate." Scan the Sensor QR Barcode provided by Endotronix personnel. On the confirmation screen, ensure there is a green checkmark and press the "Next" button.

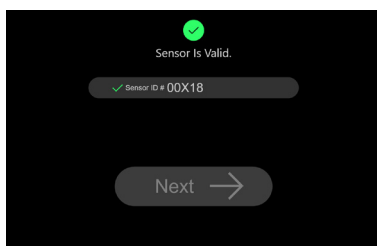

2. Scan the patient's QR Barcode Report. On the confirmation screen, ensure there is a green checkmark and press the "Next" button if the information matches.

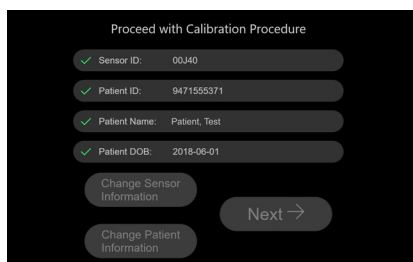

3. Set up the patient for venous access (femoral or right internal jugular) per standard protocol. Position ECG leads as far away from the right side of the patient's chest and side as possible. Endotronix recommends limb ECG leads.
4. Gain access to the patient's vein. Advance the tip of a reference catheter into the main or left PA. Avoid advancing the catheter across the Sensor body or anchor wires in the right PA, as this may damage or disrupt stability of the Sensor. Obtain a reference pressure, making sure to:
 - Adjust the pressure transducer height to mid-axillary
 - Flush the catheter and fluid line to ensure there are no air bubbles
 - Zero the measurement
5. Follow the instructions in the Calibrating the Sensor steps (Section 4.7) to finish recalibration.

7. Transport

To transport the CalEQ, turn off the computer. To do this, press the “Menu” button (three horizontal lines), select “End Session”, then select “Power Off”.

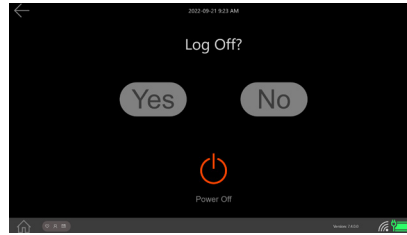

Unplug the power strip and wrap up the power cord. Disconnect the Interconnect Cable from the patient monitor (if applicable). Do not disconnect the interconnect Cable from CalEQ. Wrap the Interconnect Cable around the hooks on the basket. The CalEQ computer and Docking Stations should remain plugged into the power strip.

If the button is depressed but the Reader doesn't respond, the battery is likely depleted; return the Reader to the Docking Station and allow the Reader to charge.

8. Peri-Procedural Anticoagulation and Antiplatelet Therapy

For patients who are not being treated with chronic anticoagulant therapy, it is recommended to use dual antiplatelet therapy with aspirin and clopidogrel, (or prasugrel, ticagrelor) for 30 days post implant. Patients who are currently on anticoagulant therapy, or those in which chronic anticoagulant therapy is indicated for HF treatment should discontinue use of anticoagulant therapy 1-2 days prior to the Cordella Sensor implant and restart treatment post-implant. An INR of <1.5 is recommended prior to Sensor implant for subjects who were previously on anticoagulant therapy. The standard of care per institutional protocol as bridge therapy to Cordella Sensor placement should be used in patients who were on anticoagulant therapy (e.g., IV heparin or low molecular weight heparin).

Post 30 days, for patients not on anticoagulant therapy, continuous antiplatelet therapy with aspirin is recommended indefinitely. It is important to resume or initiate antiplatelet or anticoagulant therapy post-implant to reduce the likelihood of thrombotic events.

9. Patient Implant Card

A patient identification card is provided. Apply one of the peel-off labels from the Delivery System box onto the card. The patient identification card should be given to the patient after implantation. Advise patients to keep this card in their possession at all times.

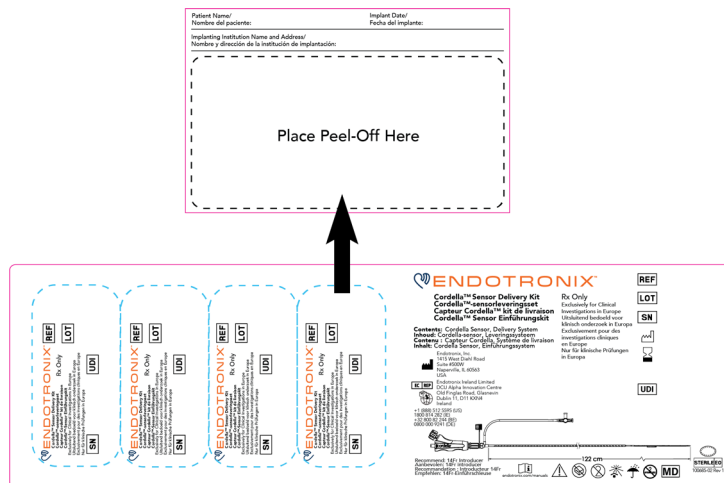

10. Audio & Visual Cues

Reader Audio Cues

Event	Sound	Required Action
Searching for Sensor	Several beeps increasing in speed	Reposition Reader to find stronger signal.
Sensor Located	Four quickly ascending, high pitched beeps, repeating three times	Strong signal found. Hold Reader in place.
Reading in Progress	Two quickly ascending beeps, repeating every ~3 seconds	Hold Reader in place (~18 seconds).
Successful Sensor Reading	Several quickly ascending, high pitched beeps	Measurement complete. Return Reader to Docking Station.
Failed Reading	Several slowly descending, low pitched beeps	Reposition Reader to find stronger signal.
Return to Docking Station	Successful Reading sound repeating periodically	Return to Docking Station. If Reader is there, check Docking Station visual cues.
Warmup	Several slowly ascending beeps	Return the Reader to the Docking Station to allow it to warm up.
Low Battery	Three quick, low pitched beeps, repeating every ~10 seconds	When accompanied by solid white light, return to Docking Station.
Contact Customer Service	Three quick, low pitched beeps, repeating every ~10 seconds	When accompanied by flashing purple light, call Customer Service.

Reader Visual Cues

Light	Event/Required Action
Solid Dark Blue	Searching for Sensor.
Slowly Flashing Dark Blue	Return to Docking Station.
Rapidly Flashing Dark Blue	Sensor located. Ready to begin reading.
Slowly Flashing Green	Reading in progress. Hold Reader in place until light becomes solid green.
Solid Green	Successful Sensor reading.
Rapidly Flashing White	Failed reading. Reposition Reader.
Solid White	Low battery. Return to Docking Station.
Alternating White, Blue, Dark Blue	Return the Reader to the Docking Station to allow it to warm up.
Rapidly Flashing Purple	Contact Endotronix Customer Service.
Light Off	Out of battery. Return to Docking Station.
Solid Blue	Reader is not paired to CalEQ. Reader is set up for home readings.

Docking Station Visual Cues

Light	Event/Required Action
Flashing White	The Reader is being charged.
Solid White	The Reader is fully charged and ready for use.
No Light	When the Reader is docked and no light is present, the Docking Station is not connected to a power source. Check that the Docking Station Power Cord is plugged into both Docking Station and the CalEQ power strip, the Reader is fully seated in the Dock, the Dock is sitting flush, and that the power strip is plugged into an outlet. If the light remains off, contact Customer Service.

11. Maintenance and Storage

11.1 Environmental Information

Store the Delivery System and Cordella Sensor in standard hospital storage conditions. Keep dry and out of sunlight.

The CalEQ computer, Docking Station, and backup Docking Station should remain plugged into the power strip. The power strip cord is to be used for mains disconnection. Reference the Equipment Specifications in Appendix B for specific storage conditions.

The Cordella Sensor and Delivery System are sterilized in a Tyvek pouch. Tyvek pouches are stored in unit boxes. The unit boxes containing the sterile Tyvek pouch should be stored in a clean, dry place with other sterile inventory.

Ensure all parts are clean and dry prior to storage.

11.2 Replacement and Repair

The Cordella Pulmonary Artery Sensor System does not require user maintenance and contains no user serviceable parts. If an issue with the system appears to require maintenance, contact Customer Service.

To maintain applicable warranties and function, Endotronix requires that only authorized personnel perform repairs. There are no user serviceable parts. Repairs made by unauthorized personnel will invalidate your warranty. For product warranty information, please contact Customer Service. Changes or modifications not expressly approved by Endotronix may void the user's authority to operate the system.



WARNING: DO NOT attempt to modify, disassemble, or otherwise alter any of the system components. If the system appears to be damaged, contact Endotronix Customer Service.

If there are defects or damage to any system component, including power accessories, request a replacement from Endotronix and follow the RMA process (see Section 14) as requested by Customer Service.

Software configuration of the CalEQ can only be performed by Endotronix authorized personnel.

12. Inspection & Cleaning Instructions

Inspect the CalEQ system regularly. If any of the inspection checkpoints apply, please contact Customer Service.

Inspection Checklist

- Power cords are not frayed or connected to unauthorized equipment. If there is a frayed power cord or if the unit is attached to unauthorized equipment, unplug the unit and notify Customer Service to obtain a new one.
- Cables are properly attached and in good condition.
- All accessories are securely attached.
- Components are not in or near water.
- Components have not been moved to an unsuitable location.
- If any component has been dropped or damaged, call Customer Service. Qualified service personnel must inspect any dropped or damaged units before they are assigned for use.

Cleaning

- Shut down the CalEQ before cleaning or disinfecting.
- Turn off the Reader by pressing and holding the small switch at the base for several seconds.
- To clean, wipe the surfaces with Super Sani-Cloth wipes or equivalent cleaner.
- Clean the system components after each use.
- DO NOT disassemble. Clean only the surfaces of the Reader, Docking Station, and CalEQ.
- DO NOT immerse any component in any liquid.
- DO NOT spray liquids directly on any component – use a pre-moistened cloth.
- DO NOT autoclave.
- DO NOT sterilize with ethylene oxide.

13. Disposal

The Cordella Sensor and Delivery System are single use devices. Once the Cordella Sensor has been deployed from the Delivery System, dispose of the Delivery System following standard hospital protocols for disposal of biohazardous materials. If the Cordella Sensor is removed from the patient for any reason (death, adverse event, etc.), then it should be contained and shipped to Endotronix following standard protocols for biohazardous materials, taking care not to damage the device. If there is an adverse event or suspected device malfunction related to the Delivery System, contact Customer Service to initiate an RMA procedure.

It is not necessary to remove the Sensor prior to cremation. Do not implant an explanted Sensor in another patient as sterility, functionality, and reliability cannot be ensured.

The Reader, Docking Station and CalEQ devices contain lithium ion batteries, which should not be discarded with municipal waste. The Reader, Docking Station, and CalEQ should be discarded following applicable electronic waste procedures. If there is an adverse event or suspected device malfunction related to the Reader, Docking Station, or CalEQ, contact Customer Service to initiate an RMA procedure.

14. Return Materials Authorization (RMA)

If Customer Service requests that the equipment be returned, please follow the directions below.

1. Carefully pack the equipment in the original shipping box or equivalent with its original protective packaging materials or equivalent as instructed by Customer Service.
2. Include the RMA number given to you by Customer Service on the outside of the shipping container. Ship all equipment and signed equipment return list to:

RMA#
Customer Service Department, Repairs
Endotronix, Inc.
1415 West Diehl Road
Suite #500W
Naperville, IL 60563
U.S.A

15. Troubleshooting

15.1 Implant Procedure & Delivery System

Delivery System Connection

- If the Stability Sheath becomes disconnected from the Torque Catheter during the procedure, reconnect the Stability Sheath to the Torque Catheter and hand tighten the torque luer connection to stabilize.

Advancing the Delivery System

- If difficulty is experienced advancing the Delivery System through the heart structures, retract the system proximal to the right atrium and apply torque to the handle to rotate the Cordella Sensor such that it is on the inner curve of the pathway to the right pulmonary artery.

Kinked Guidewire

- If the guidewire becomes kinked, the Delivery System may bind to it and prevent the Delivery System from being advanced or retracted.

Sensor Orientation before Deployment

- If rotational placement of the Cordella Sensor in the target segment is difficult to achieve (e.g. excessive rotation), try incremental application of torque (i.e. "ratcheting") rather than continuously increasing application of torque to the handle.
- If rotating the Cordella Sensor while in target vessel is difficult, you may retract the system into a larger vessel, then rotate to the desired orientation, then advance into position in the target segment.

Aborted Procedure

- If the decision is made not to deploy the Cordella Sensor after it has been inserted through the introducer sheath:
 - Slowly retract the Delivery System until the Cordella Sensor is in contact with the distal tip of the introducer. Almost the entire length of the Delivery System will be removed, and the Cordella Sensor will catch or snag on the introducer tip.
 - At this point, while holding the introducer in place, rotate the handle of the Delivery System while keeping it in slight tension (DO NOT ACTIVELY PULL).
 - After a minimum of 5 rotations of the handle, the Cordella Sensor should have corkscrewed into the distal portion of the introducer and it will be safe to retract the Delivery System and Cordella Sensor slowly until they are fully removed. If high resistance is met or the introducer is being dislodged, insert the Delivery System approximately 5 mm into the introducer and repeat the removal procedure steps listed above, rotating the handle in the opposite direction. If high resistance is still met or the introducer continues to dislodge, consider removing both the Delivery System and introducer sheath in tandem.
 - DO NOT reuse the same Delivery System and Cordella Sensor after removal from the introducer. Return the used Delivery System and Sensor to Endotronix following the RMA process described above.

Reference Pressure Measurement

- After Sensor deployment and torque catheter removal, if the stability sheath becomes kinked and a pressure reading cannot be obtained, advance the sheath forward or backward 2-3 cm. Flush stability sheath to confirm kink has been resolved prior to performing the fluid filled calibration.
- If the reference pressure measurement through the stability sheath is suspected as being inaccurate, reinsert the PA catheter for use as the reference pressure measurement device.

15.2 Pairing and Interrogating the Cordella Sensor

Scanning Sensor or Patient QR Barcode

- If no information is displayed after attempting to scan the QR barcode:
 1. Check that the barcode aimer circle is illuminated. If the aimer is not illuminated, check that the power cord for the barcode scanner is connected properly to the handle and the CalEQ. If the barcode scanner is not functioning properly, contact Endotronix Customer Service.
 2. Check that the QR barcode is not smeared, rough, scratched, or exhibiting voids. If the QR barcode on the Delivery System packaging is damaged, contact Endotronix Customer Service for assistance. If the QR barcode from the QR Barcode Report is damaged, re-print the QR Barcode Report from PMP.

Reader-CalEQ Communication

- If the Reader is picked up from the Docking Station but the screen remains on "Undock Reader," wait a few minutes for the CalEQ to recognize that the Reader is undocked. If after a few minutes, the screen remains on "Undock Reader", turn off and redock the Reader, verify the Reader is paired to CalEQ, then repeat the procedure with the backup Reader and contact Endotronix Customer Service post-procedure.

Sensor Interrogation Check Failure

- If the Reader is unable to find the Cordella Sensor signal when placed on the Delivery System packaging, even after repositioning the Reader around and to the side of the box, DO NOT use the Delivery System and instead repeat the steps with a new Delivery System package and contact Endotronix Customer Service after the procedure.

15.3 Calibrating the Cordella Sensor

Reader Power

- If the Reader does not turn on, as indicated by audio and visual cues, after pressing and holding the power button for several seconds, place the Reader back on the Docking Station, ensuring that the Docking Station power cord is plugged into the power strip and the power strip is plugged into an outlet. If the Docking Station LED flashes, the Reader battery is likely depleted and must be charged; the backup Reader should be used. If the Reader does not turn on, even when charged, use the backup Reader and contact Endotronix Customer Service after the procedure.

Difficulty Locating Sensor Signal

- If the Reader is having difficulty taking a reading or is unable to achieve >80% signal strength, move patient monitoring systems, cell phones, pagers, and other equipment that could cause interference as far away from the patient's chest as possible.

Repeated Calibration Errors or Reader Problems

- If the Reader continues to have difficulties, calibration can be completed after the implant procedure. Record the reference measurements during the procedure, then follow the calibration steps later. It is important that the patient's position during post-procedure calibration closely matches their position when the reference measurements were taken. Ensure that the patient's body, legs, and arm positions, as well as pillow use are the same. The patient should be breathing normally and should refrain from speaking.

Incorrect Reference Pressure

- If the wrong reference pressure measurement numbers are entered, press "Calibrate Again" and complete the calibration workflow again.

Reader Not Found

- If the Reader is picked up from the Docking Station and CalEQ says "Reader Not Found," repeat the procedure with the backup Reader and contact Endotronix Customer Service to initiate the RMA process.

Upload Calibration Data after Restoring Wireless Network Connection

- If the option to "Upload Later" is chosen instead of "Upload to Cloud," navigate to Calibration History to upload the calibration data as soon as connection to a wireless network is restored. To view Calibration History, press the "Menu" button in the bottom left corner, then the "Calibration History" button. Selecting "Upload to Cloud" will upload all data that has not been previously uploaded. If connection to a wireless network cannot be restored, contact Endotronix Customer Service for assistance.

15.4 Anomalous PA Pressure Data

In the event that anomalous PA pressure data is observed in the PMP, the patient's Cordella Sensor may require recalibration.

Examples of anomalous PA pressure data may include:

- Gradual mean pressure changes without a corresponding proportional change in pulse pressure (systolic- diastolic pressure)
- Largely negative mmHg values for mean PA pressure
- Large, sustained one-time shifts in PA pressure
- Indiscernible PA pressure waveform
- Significant reduction in PA pulse pressure

If you suspect the patient's Cordella Sensor may require recalibration, contact Customer Service.

16. Useful Life

The useful life of the Cordella Sensor is tested to ten (10) years. The tested service life of the Reader and Docking Station is four (4) years, and the tested service life of CalEQ is five (5) years.

17. Clinical Study Information

17.1 Introduction

In its final design, the PROACTIVE-HF study was a prospective, single-arm, open-label, multi-center clinical trial to evaluate the safety and effectiveness of the Cordella PA Sensor System in NYHA functional class III HF patients. Adults with a diagnosis of HFrEF or HFpEF and NYHA functional class III symptoms were eligible for enrollment if they were treated with GDMT for a minimum of 3 months (stable doses at least 30 days prior to enrollment) and, within the past year, the patient had either 1) one HF hospitalization, or 2) HF treatment in a hospital day care setting, or 3) urgent outpatient clinic HF visit for IV diuretics, or 4) a persistently elevated NT-proBNP level at the time of screening. The Institutional Review Board of each participating center approved the study protocol, each patient provided written informed consent, and events were adjudicated by a Clinical Events Committee.

All patients enrolled into PROACTIVE-HF received the Cordella HF System (recording weight, BP, HR, and SpO₂). After demonstrating compliance with utilization, all patients underwent right heart catheterization and deployment of the Cordella PA pressure sensor into the interlobar right pulmonary artery, provided that the RPA downturn diameter is 12-26 mm for secure stabilization of the sensor. Patients were instructed to take their daily PAP measurements along with their weight, BP, HR, SpO₂, and HF symptoms by using Bluetooth-connected peripherals. Vital signs were visible to both clinicians and patients, while pulmonary artery pressures were visible to the clinicians only. All patients were then managed according to the trial specific seated mPAP treatment guidelines, with a target seated mean pulmonary artery pressure goal of 5-20 mmHg, achieved through titration of diuretics and GDMT via a trial specific treatment guideline as shown in Figure 1.

Figure 1: PROACTIVE-HF Treatment Guidelines for Seated Mean Pulmonary Artery Pressure

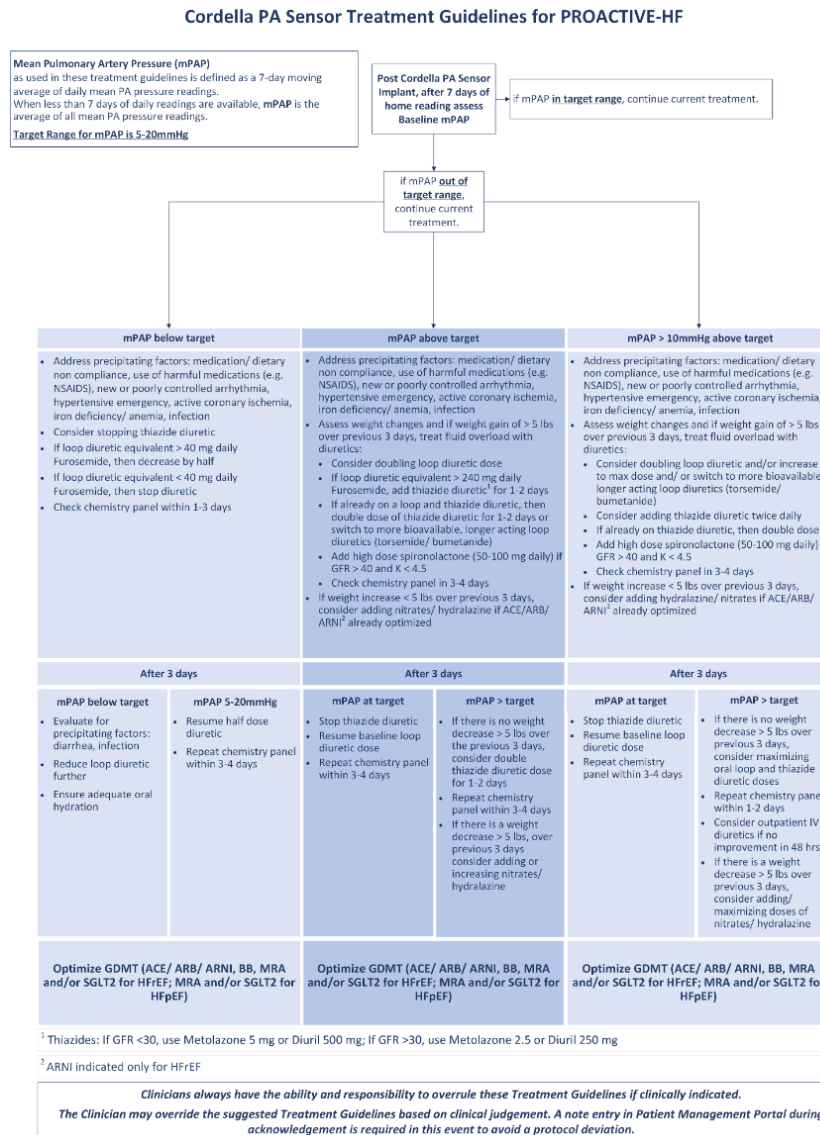

Of note, the aforementioned final study design resulted from a deviation of the original study design for the PROACTIVE-HF, which was initially designed by the manufacturer of this device to be a prospective, randomized, controlled, multi-center clinical trial. In the initial phases of this trial, patients were initially randomized 1:1 to either Control or Treatment groups. All readings (pulmonary artery pressure and vital signs) were visible to clinicians of patients within the treatment arm, while only the vital signs were visible to treatment arm patients themselves. However, once PROACTIVE-HF began enrolling subjects, prospective clinical evidence from CardioMEMS was published in 2019-2021, including the GUIDE-HF Trial in 2021. The GUIDE-HF Trial was a prospective, randomized, controlled, single-blind, multicenter, pivotal clinical trial whose purpose was to establish a reasonable assurance of safety and effectiveness of the CardioMEMS HF System to guide the treatment of patients with New York Heart Association (NYHA) Class II - IV heart failure. The GUIDE-HF Trial demonstrated a positive clinical benefit of PAP-guided heart failure management in NYHA functional class III patients using the CardioMEMS device. With this new evidence,

in December 2021 the manufacturer of this device petitioned to the Food and Drug Administration (FDA), to change the study design from a randomized controlled clinical trial to a single-arm trial (described above), with pre-specified safety and efficacy endpoints to provide objective evidence of a similar risk-benefit profile to the CardioMEMS HF System in NYHA functional class III subjects. At the time of crossover to a single-arm, patients in the randomized Control arm (Cohort #1) were unblinded and both clinicians and patients, who opted, in received immediate access to mPAP data and all patients were then managed according to the trial specific seated mPAP treatment guidelines. Cohort #1 subjects did not contribute to the primary safety and efficacy endpoints of PROACTIVE-HF but contributed to a patient engagement substudy. Patients in the randomized Treatment arm (Cohort #2) continued follow-up per protocol and, along with the newly enrolled single arm Treatment group (Cohort #3), contributed to the primary safety and efficacy endpoints of PROACTIVE-HF.

17.2 Study Objectives

The objectives of this study are to demonstrate the safety and efficacy of the Cordella PA Sensor System.

17.3 Study Design

Patients were treated between January 10, 2020 and September 30, 2023. The database for this PMA reflected data collected through September 30, 2023 and included 456 patients. There were 77 investigational sites.

This study was a prospective, multi-center, open-label, single-arm clinical trial to assess device safety and efficacy of the Cordella PA Sensor System in NYHA Class III Heart Failure patients compared to a Performance Goal (PG) of the rate of HF hospitalizations or all-cause mortality at 6 months based on a meta-analysis on the combined cohorts of CHAMPION-HF, CardioMEMS Post approval study, MEMS-HF, GUIDE-HF (NYHA Class III cohort), and LAPTOP-HF (control group only). This trial was conducted under the IDE# G190020. The patient population was composed of patients with a HF diagnosis of > 3 months with either preserved or reduced LVEF.

Subjects in this trial were categorized into three (3) different cohorts:

Cohort #1- Previously enrolled Control Arm subjects

- Upon change to single arm, subjects in this cohort were unblinded to their PAP measurements and informed about their previous group assignment and continue their Follow-up visit schedule.
- Additionally, subjects were asked, throughout the remaining Follow-up period, to complete a regular subject survey on their experience with PAP Measurements and PAP values.
- Upon change to single arm, clinicians were unblinded to PAP measurements and started managing the patients to target PA pressures per protocol/ CIP and according to Guideline Directed Medical Therapy (GDMT).
- Additionally, the clinical site was asked to contact the subject on a regular basis to discuss their PAP values.
- Separate subgroup analysis (safety and effectiveness) were performed.

Cohort #2- Previously enrolled Treatment Arm subjects

- As of month 12 subjects in this cohort were able to see their own PAP measurements for the remaining duration of the study.
- Clinicians continued to manage the patients to target PA pressures per protocol/CIP and according to GDMT.
- All primary and secondary safety and effectiveness analyses were performed.

Cohort #3- Newly enrolled subjects

- Subjects participated in the Screening/ Enrollment Visit, Cordella PA Sensor Implant Visit, and Follow-Up Visits.
- Clinicians managed the patients to target PA pressures per protocol/ CIP and according to GDMT.
- As of month 12, subjects in this cohort were able to see their own PAP measurements for the remaining duration of the study.
- All primary and secondary safety and effectiveness analyses were performed.

The Cordella PA Sensor was implanted in conjunction with a right heart catheterization (RHC) procedure. During this visit, the Cordella PA Sensor, which is pre-mounted on a catheter Delivery System, was introduced via percutaneous venous access to the pulmonary artery. Once deployed, the Sensor PAP was calibrated using the Delivery System's fluid-filled catheter for independent reference measurements. The calibration coefficients for that Sensor/Reader/ Subject were stored in a database, allowing for consistent PAP calculations throughout the study duration. Also, at the Screening Visit, eligible subjects were provided with the commercially available Cordella HF System to measure BP, HR, SpO₂ and weight.

Subjects were observed until stable and discharged home with instructions to take their PAP measurements daily in addition to their weight, BP, HR and SpO₂, which were all wirelessly transmitted to a secure website for review using the myCordella Patient Management Portal.

Visibility to patients' daily data trends enabled the clinician to proactively manage the patients to target PA pressures per protocol and according to GDMT. The clinician contacted all subjects on a regular basis to discuss their health status and all patients were treated according to GDMT. All Subjects will return for follow up visits at 1, 6, 12, 18, 24 months, as well as at Year 3, 4 and 5, after the Cordella PA Sensor implant, or until study termination. The 3 month follow-up visit was performed as a remote/ virtual telemonitoring visit.

All subjects who received a Cordella PA Sensor Implant were followed for 6 months for the Primary Efficacy and Primary Safety Endpoints and will be followed for up to 5 years post implant. Additional monitoring of safety and efficacy assessments will be performed throughout the study duration, including evaluation of subject functional and health status, adverse events, Heart Failure (HF) related hospitalizations or equivalent (e.g., intravenous (IV) diuretics).

A total of 75 sites (71 US/4 EU) enrolled a subject in this trial. A subject is considered enrolled if the subject signed the consent form, completes the screening visit, and is reviewed by the Eligibility Committee. A subject is considered to be a screen failure if the subject signed the consent form but was subsequently determined ineligible based on the trial inclusion and/or exclusion criteria prior to implant.

The trial began in the USA with the first site for the trial initiated on November 8, 2019, and Enrollment into the trial started on January 10, 2020. After approval of protocol amendment V7.0 (November 21, 2021), the amendment not only increased the number of participating centers to one-hundred twenty (120) in the United States (US) and Europe (EU), as well as a change in trial design from a randomized to a single arm trial. After the approval of protocol amendment V7.0 (November 21, 2021) in December 2021 all sites were consequently converted to this single arm trial.

Enrollment was completed on March 8, 2023, and the last subject was implanted on March 31, 2023.

Out of the 738 enrolled subjects, 528 subjects received an implant (Figure 3). Five-hundred twenty-eight (528) are a combination of 72 subjects in Cohort # 1, the previously enrolled Control Arm subjects; 88 subjects in Cohort# 2, the previously enrolled Treatment Arm subjects; and 368 subjects in Cohort# 3, the newly enrolled subjects. One-hundred twenty-five (125) subjects failed screening and 85 subjects were withdrawn prior to implant. Thirty-seven (37) subjects had an aborted implant.

17.4 Clinical Inclusion and Exclusion Criteria

Enrollment in the PROACTIVE-HF study was limited to patients who met the following inclusion criteria:

1. Subject has given written informed consent
2. Male or female, at least 18 years of age
3. Diagnosis and treatment of HF (regardless of left ventricular ejection fraction (LVEF)) for ≥ 3 months and NYHA Class III HF at time of Screening
4. Subjects should be on stable, optimally titrated medical therapy for at least 30 days, as recommended according to current American Heart Association (AHA)/American College of Cardiology (ACC) guidelines as standard-of-care for HF therapy in the United States, or current European Society of Cardiology (ESC) guidelines for HF treatment in Europe, with any intolerance documented
5. Subjects who qualified for the following:
 - a. HF related hospitalization, in the past year i.e. one calendar day change
 - b. HF treatment in a hospital day-care setting
 - c. Or urgent outpatient clinic HF visit for IV diuretics within 12 month (last hospitalization should be 30 days before Screening /Enrollment)
 - d. Or N-terminal pro-Brain Natriuretic Peptide (NT-proBNP) at time of Screening/ Enrollment defined as:
 - Subjects with LVEF $\leq 50\%$: NT-proBNP ≥ 1500 pg/mL.
 - Subjects with LVEF $> 50\%$: NT-proBNP ≥ 800 pg/mL.Thresholds for NT-proBNP (for both LVEF $\leq 50\%$ and LVEF $> 50\%$) will be corrected for body mass index (BMI) using a 4% reduction per BMI unit over 25 kg/m²
6. Subjects should be on diuretic therapy
7. Subjects who are physically able to hold the myCordella™ Handheld Patient Reader unit (approximate weight 1.3lb) against the ventral thoracic surface for up to 2 minutes per day while in a seated position, as well as dock and undock the myCordella™ Handheld Patient Reader
8. Subjects with sufficient eyesight, hearing, and mental capacity to respond to the myCordella™ Handheld Patient Reader's audio/visual cues and operate the myCordella™ Handheld Patient Reader
9. Subject has sufficient Cellular and/ or Wi-Fi Internet coverage at home
10. Subject agrees to return to the treating Investigator for all scheduled follow up visits and can return to the hospital for follow up

Patients were permitted to enroll in the PROACTIVE-HF study if they met any of the following exclusion criteria:

1. Intolerance to all neuro-hormonal antagonists (i.e., intolerance to ACE-I, ARB, ARNI, and beta-blockers) due to hypotension or renal dysfunction
2. ACC/AHA Stage D refractory HF (including having received or currently receiving pharmacologic circulatory support with inotropes)
3. Subjects with history of recurrent pulmonary embolism (≥ 2 episodes within 5 years prior to Screening Visit) and/or deep vein thrombosis within 3 months of the Screening Visit
4. Subjects who have had a major CV event (e.g., myocardial infarction, stroke) within 3 months of the Screening Visit
5. Unrepaired severe valvular disease
6. Subjects with significant congenital heart disease that has not been repaired and would prevent implantation of the Cordella PA Sensor or mechanical/tissue right heart valve(s)
7. Subjects with known coagulation disorders
8. Subjects with a hypersensitivity or allergy to platelet aggregation inhibitors including aspirin, clopidogrel, prasugrel, and ticagrelor; or patients unable to take dual antiplatelet or anticoagulants for one- month post implant
9. Known history of life threatening allergy to contrast dye.
10. Subjects whereby RHC is contraindicated
11. Subjects with an active infection at the Sensor Implant Visit
12. Subjects with a GFR <25 ml/min or who are on chronic renal dialysis
13. Implanted with CRT-P or CRT-D for less than 90 days prior to screening visit
14. Received or are likely to receive an advanced therapy (e.g., mechanical circulatory support or lung or heart transplant) in the next 12 months
15. Subjects who are pregnant or breastfeeding
16. Subjects who are unwilling or deemed by the Investigator to be unwilling to comply with the study protocol, or subjects with a history of non-compliance
17. Severe illness, other than heart disease, which would limit survival to <1 year
18. Subjects whose clinical condition, in the opinion of the Investigator, makes them an unsuitable candidate for the study
19. Subjects enrolled in another investigational trial with an active Treatment Arm
20. Subject who is in custody by order of an authority or a court of law

17.5 Follow-up Schedule

All patients were scheduled to return for follow-up examinations at 1, 6, 12, 18, 24 months, as well as at Year 3, 4 and 5, after the Cordella PA Sensor implant, or until study termination. Adverse events and complications were recorded at all visits. The key timepoints and assessments are shown in the Table 1:

Table 1. PROACTIVE-HF / ETX-HFS-PA-03: Study Visit Schedule

Assessment	V1: Screening/ Enrollment (30 days) ⁵	V2: Cordella PA Sensor Implant Visit	V3: Month 1 (±7 days)	V4 ¹¹ : Month 3 (±7 days)	V5: Month 6 (±14 days)	V6: Month 12 (±30 days)	V7 to V8: Months 18, 24 (±30 days)	V9 to V11 Year 3, 4, 5 (±30 days)
Informed Consent	X							
Subject Demographics	X							
Study Eligibility Review and Committee Approval	X							
Cardiac/Medical & Surgical History	X							
Physical Exam, height, weight, and vital signs ^{1,5}	X	X	X ¹²		X	X	X	X
12-Lead ECG with Interpretation	X				X	X	X	X
Urinalysis ²	X							
Safety Labs (Chemistry/Hematology/ aPTT/ INR)	X				X	X	X ⁴	X
Serum NT-pro BNP	X		X	X ¹²	X	X	X	X
aPTT/ INR (if indicated)								
Echocardiogram ³	X					X		X
Subject Training: Cordella™ HF System ¹⁴	X							
Subject Training: CorPASS		X						
Cordella™ PA Sensor Implant		X						
Cordella System Use (daily)	X	X	X	X	X	X	X	X
Cordella™ PAP - dia/sys/mean/pulse		X ⁹	X ^{5,6}	X ^{5,6}	X ^{5,6}	X ^{5,6}	X ^{5,6}	X ⁶
RHC PAP / RAP/ PCWP/ CO/ CI/ RVP ⁸		X						X ¹⁷
Subject Status	X		X	X	X ¹⁰	X ¹⁰	X	X
6- Minute Walk Test	X				X	X ⁷	X ^{4,7}	X ⁷
NYHA Functional Classification	X ¹⁶		X	X	X	X	X	X
KCCQ Quality of Life Questionnaires ⁵	X		X	X	X	X	X	X
Concurrent/Cardiac Medications	X	X	X	X	X	X	X	X
Adverse Events	X	X	X	X	X	X	X	X
Health Economic Questionnaire							X ⁴	
Subject Survey (optional)/ Cohort #1 only ¹³	1. Month 1 after Unblinding 2. Quarterly until V11 / Year 5							
Site Survey (optional)/ Cohort #1 only ¹³	1. Month 1 after Unblinding 2. Quarterly until V11 / Year 5							
1. Full Physical Examination and Height performed at Screening Visit only 2. Urine (V1) pregnancy test for females 3. Echo may be obtained within 3 or 6 months of Screening details are in section 8.1.10 4. At Month 24 only 5. via myCordella™ Patient App at home prior to visit. Baseline KCCQ will be completed on myCordella tablet following Cordella System distribution at Screening Visit 6. via myCordella™ Patient App seated and supine 7. Additional PAP Measurements will be obtained before and after 6-minute walk test 8. Additional RHC as needed for Re-calibration purposes at the clinician's discretion	9. Via CalEQ 10. Incl. question on assigned treatment at Visit 5 and 6 11. Visit should be completed remote/virtually 12. If available 13. After subject gets unblinded to PAP Pressures at V6 or cross-over whatever comes first 14. Subject training on and distribution of the commercial Cordella™ System (should occur at Screening Visit (Visit 1). 15. Some study procedures need to be repeated in case a subject is implanted >30 days after Visit 1, details are in section 8.3.1. 16. may be obtained within the 30 day Study Visit 1 window 17. At V9/ Year 3 only							

17.6 Clinical Endpoints

With regards to safety, the study had primary and secondary safety endpoints which are discussed below:

17.6.1 Safety Endpoints

Primary Safety Endpoints:

Freedom from device or system-related complications (DSRC) at 6 months will be tested against the null rate of 90%. Based on a one sample test of a proportion, a sample size of

1. 450 patients provides greater than 95% power assuming a population rate of 95% based on a two-sided Type I error rate of 5%.
2. Freedom from pressure sensor failure at 6 months will be tested against a null rate of 95%

Secondary Safety Endpoints:

1. Frequency of serious adverse events (SAEs) throughout the study
2. Frequency of implant procedure and procedure related adverse events
3. Pressure sensor failure rate throughout the study

With regards to effectiveness, the study had primary and secondary efficacy endpoints which are discussed below.

With regard to success/failure criteria, results of individual CardioMEMS studies and an internally derived meta-analysis were considered in determining the Primary Endpoint Performance Goal (PG) for the re-designed study. The meta-analysis was performed on the combined cohorts of CHAMPION-HF, CardioMEMS Post approval study, MEMS-HF, GUIDE-HF (NYHA Class III cohort), and LAPTOP-HF (control group only) as shown in Figure 2.

Figure 2: Results of Individual CardioMEMS Studies and Meta Analysis For Determining the Primary Endpoint Performance Goal

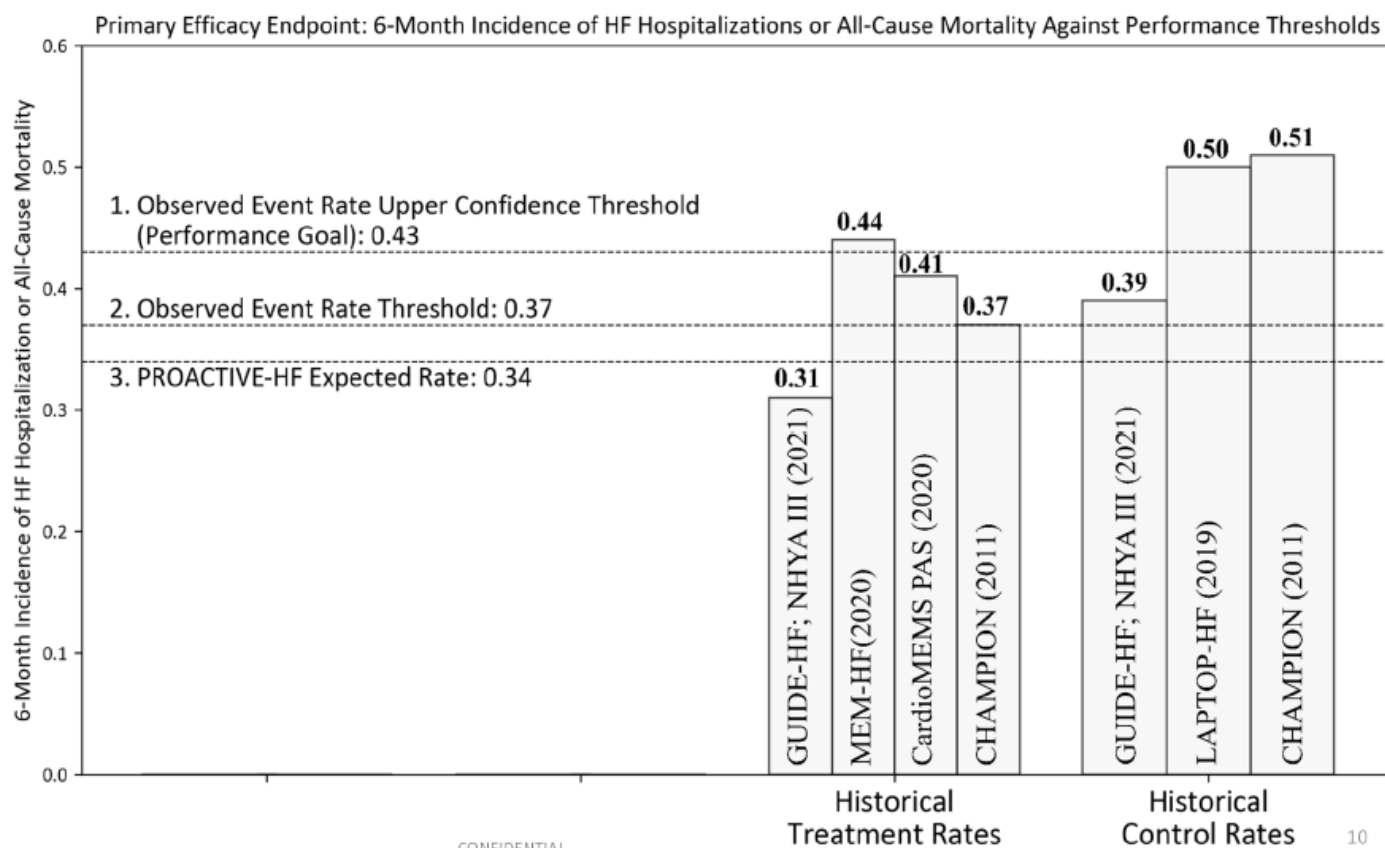

To meet the new objectives of the study, observed event rates in the single-arm PROACTIVE-HF should be similar to observed event rates in the treatment arm of CardioMEMS studies and lower than observed event rates in the control arm of CardioMEMS studies. Therefore, we set the PG below the meta-analysis upper bound 95% confidence interval of CardioMEMS treated patients, and below the meta-analysis estimates of CardioMEMS control patients and adjusted the goal downwards to account for a potential impact of treatment with SGLT2i. Furthermore, we also require that the single-arm PROACTIVE-HF observed event rate be lower than both the meta-analysis estimate of CardioMEMS treatment patients, and the lowest observed event rates of CardioMEMS control patients, further adjusted down by potential impact of SGLT2i.

Primary Efficacy Endpoint:

The primary endpoint was the 6-month incidence of HF related hospitalizations (HFH) or all-cause mortality.

For the primary endpoint of HFH and all-cause mortality at 6 months, the PG is 0.43 events per patient 6-month and, for study success, the upper confidence bound of the observed event rate for the planned study must be less than the PG. Additionally, the observed event rate must be lower than 0.37 events per patient 6-month.

Evaluating the upper bound of the confidence interval for the rate, ensures:

- 1) the observed rate will be comparable to prior studies of active treatment (highest observed value = 0.44).
- 2) the observed rate will be less than the mean rate from meta-analysis of prior studies of treatment and control, and
- 3) the observed rate will be less than the lowest rate observed in the control studies (GUIDE-HF). The added requirement for the observed rate to be less than 0.37 provides further assurance that results are comparable to studies of prior treatment.

Based on this, the study will implant 450 subjects (single arm cohorts) leading to an expected evaluable cohort of 406 subjects. With a PG of 0.43 and a one-sided 0.025 alpha level, the study will have greater than 80% power assuming a population treatment rate of 0.34.

Secondary Efficacy Endpoints:

1. The first secondary efficacy endpoint is incidence of HF Hospitalizations or all-cause mortality at 12 months compared to a PG. The PG of 0.70 for the first secondary endpoint of 12-month incidence of HFH or all-cause mortality was derived from clinically relevant, contemporary studies of NYHA Class III HF subjects. Additionally, we require the observed event rate to be less than 0.59.
2. Number of HFH at 6 and 12 months post-implant compared to the number of HFH in the 6 and 12 months prior to implant
3. Comparison of the number of HFH or emergency department / hospital outpatient IV diuretic visits of Cohort #1 and Cohort #2 at 6 and 12 months post-implant
4. Change of NT-pro BNP from baseline through 6 and 12 months
5. Combined outcome of:
 - a. First and recurrent HFH
 - b. Emergency department / hospital outpatient IV diuretic visits
 - c. All-cause mortality

At 6 months, added together with equal weighting into a total number of events

6. HFH or emergency department / hospital outpatient IV diuretic visits at 6 and 12 months
7. Cardiac and all-cause mortality
8. Days alive and out of the hospital (DAOH)
9. IV diuretic visits
10. Heart failure related medication changes
11. Change in PAP:
 - a. From baseline through 6 and 12 months in subjects with a baseline mean PAP
 - i. Above target range
 - ii. Within or below target range
 - iii. Overall
 - b. Before and after 6-minute walk test (6MWT)
12. Percentage of device success as documented by ability of the system to successfully transmit PAP data
13. Patient outcome measures, measured by KCCQ
14. Functional status improvement, as measured by NYHA and 6MWT
15. Health economic analysis

17.6.2 Accountability of PMA Cohort

At the time of database lock, 738 patients had enrolled in the PROACTIVE-HF study (85.5% of screened patients) and a total of 528 patients (71.5% of enrolled patients) implanted with the device are available for analysis at the completion of the study on 29 September 2023. Implanted subjects were included in either the randomized Control Arm prior to the trial redesign (Cohort #1, N = 72 subjects), in the randomized Treatment Arm prior to the trial redesign (Cohort # 2, N=88 subjects), or in the Treatment Arm after the trial redesign (Cohort #3, N=368 subjects). Subjects in Cohorts #2 and #3 (N = 456) contribute to the primary safety and efficacy endpoints in PROACTIVE-HF. Subjects in Cohort #1 contribute to a substudy examining patient engagement with pulmonary artery pressures.

- a. Intent-to-Treat Population (ITT), includes all enrolled subjects intended to receive the Cordella PA Sensor who entered the Cath Lab, including those in whom Implant Procedure was not completed for whatever reason (e.g., Cordella PA Sensor Implant could not be performed due to anatomical reasons) from Cohort #2 and #3. The ITT was used for all analyses of safety endpoints.
- b. Modified Intent-to-Treat Population (mITT), includes all implanted subjects from Cohort #2 and Cohort #3. All primary and secondary effectiveness analyses were performed on the mITT.

- c. Per Protocol Population (PP), includes all mITT subjects without any major protocol deviations. All primary and secondary safety and effectiveness analyses were performed in addition on PP population. If PP and mITT populations were identical, analysis was performed based on mITT only.
- d. Cohort #1- Previously enrolled Control Arm subjects- Population, this subgroup includes all Cohort #1 (previously enrolled Control Arm) subjects and was reported separately for all endpoints.

The trial enrollment and subject population are presented below in Figure 3.

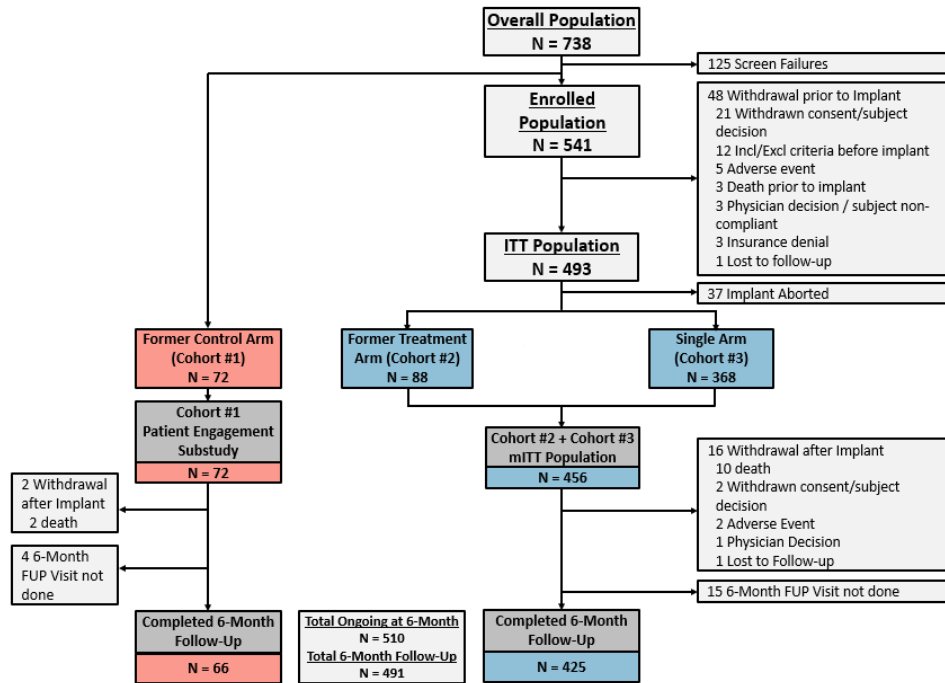

Figure 3: PROACTIVE-HF / ETX-HFS-PA-03: Patient Disposition

17.6.3 Study Population Demographics and Baseline Parameters

The demographics of the study population are typical for a single arm study performed in the US.

Study Population and Baseline Parameters

mITT & mITT Stratified by Cohort Number

There were some differences between the cohorts as illustrated in the Table below, for example the proportion of patients in Cohort #3 on SGLT2i at baseline was greater than that of Cohort #1 (64.1% vs. 29.2%) and Cohort #2 (64.1% vs. 33.0%). Table 2 presents the demographics and patient characteristics by the mITT population and stratified by Cohort assignment.

Table 2. Demographics for mITT, Cohort #1, Cohort #2, and Cohort #3

Characteristic	mITT (N=456)	Cohort #1 (N=72)	Cohort #2 (N=88)	Cohort #3 (N=368)
Demographics				
Age (years), Mean (SD)	63.5 (12.5)	65.9 (11.3)	64.5 (11.5)	63.3 (12.8)
Male, n (%)	276 (60.5%)	42 (58.3%)	56 (63.6%)	220 (59.8%)
Female, n (%)	180 (39.5%)	30 (41.7%)	32 (36.4%)	148 (40.2%)
Weight (kg), Mean (SD)	105.8 (25.8)	102.9 (22.8)	102.0 (23.3)	106.7 (26.4)
Height (cm), Mean (SD)	172.0 (10.6)	171.3 (11.3)	172.5 (9.9)	171.9 (10.8)
Body mass index (kg/m ²), Mean (SD)	35.9 (8.8)	35.3 (8.4)	34.4 (7.8)	36.2 (9.0)
Race				
White, n (%)	347 (76.1%)	56 (77.8%)	68 (77.3%)	279 (75.8%)
Black, n (%)	84 (18.4%)	11 (15.3%)	14 (15.9%)	70 (19.0%)
Asian, n (%)	7 (1.5%)	0 (0%)	3 (3.4%)	4 (1.1%)
Hawaiian or Pacific Islander, n (%)	3 (0.7%)	1 (1.4%)	1 (1.1%)	2 (0.5%)
American Indian/Alaskan native, n (%)	2 (0.4%)	1 (1.4%)	1 (1.1%)	1 (0.3%)
Other, n (%)	4 (0.9%)	0 (0%)	0 (0%)	4 (1.1%)
Race not reported, n (%)	9 (2.0%)	3 (4.2%)	1 (1.1%)	8 (2.2%)
Ethnicity				
Hispanic or Latino, n (%)	20 (4.4%)	5 (6.9%)	3 (3.4%)	17 (4.6%)
Not Hispanic or Latino, n (%)	401 (87.9%)	61 (84.7%)	81 (92.0%)	320 (87.0%)
Ethnicity not reported, n (%)	13 (2.9%)	2 (2.8%)	0 (0%)	13 (3.5%)
Unknown, n (%)	22 (4.8%)	4 (5.6%)	4 (4.5%)	18 (4.9%)

Characteristic	mITT (N=456)	Cohort #1 (N=72)	Cohort #2 (N=88)	Cohort #3 (N=368)
Smoking History				
Never, n (%)	210 (46.1%)	34 (47.2%)	33 (37.5%)	177 (48.1%)
Previous, n (%)	209 (45.8%)	31 (43.1%)	43 (48.9%)	166 (45.1%)
Smoker, n (%)	37 (8.1%)	7 (9.7%)	12 (13.6%)	25 (6.8%)
Smoking History				
Never, n (%)	210 (46.1%)	34 (47.2%)	33 (37.5%)	177 (48.1%)
Previous, n (%)	209 (45.8%)	31 (43.1%)	43 (48.9%)	166 (45.1%)
Smoker, n (%)	37 (8.1%)	7 (9.7%)	12 (13.6%)	25 (6.8%)
Heart Failure Ejection Fraction				
LVEF ≤ 40% (HFrEF), n (%)	208 (45.6%)	33 (45.8%)	40 (45.5%)	168 (45.7%)
LVEF ≥ 50% (HFpEF), n (%)	201 (44.1%)	31 (43.1%)	37 (42.0%)	164 (44.6%)
40% < LVEF < 50% (HFmrEF), n (%)	45 (9.9%)	8 (11.1%)	10 (11.4%)	35 (9.5%)
Medical History/Surgical History				
Diabetes mellitus, n (%)	161 (35.3%)	26 (36.1%)	30 (34.1%)	131 (35.6%)
Chronic kidney disease, n (%)	198 (43.4%)	37 (51.4%)	32 (36.4%)	166 (45.1%)
Chronic obstructive pulmonary disease, n (%)	92 (20.2%)	15 (20.8%)	21 (23.9%)	71 (19.3%)
Coronary artery bypass graft, n (%)	81 (17.8%)	12 (16.7%)	15 (17.0%)	66 (17.9%)
Percutaneous coronary intervention, n (%)	134 (29.4%)	23 (31.9%)	28 (31.8%)	106 (28.8%)
Valve repair / replacement, n (%)	21 (4.6%)	5 (6.9%)	6 (6.8%)	15 (4.1%)
Heart Failure History				
Time since first diagnosis of HF [months], Mean (SD)	58.1 (68.4)	66.3 (62.5)	54.0 (59.0)	59.1 (70.5)
Time since first diagnosis of HF [months], Median	33.08	46.98	31.67	33.53
Time since first diagnosis of HF [months], Min	2.97	0.03	2.97	3.03
Time since first diagnosis of HF [months], Max	454.37	257.73	309.43	454.37
Etiology of Heart Failure				
Ischemic, n (%)	143 (31.4%)	26 (36.1%)	33 (37.5%)	110 (29.9%)
Non-Ischemic, n (%)	313 (68.6%)	46 (63.9%)	55 (62.5%)	258 (70.1%)

Characteristic	mITT (N=456)	Cohort #1 (N=72)	Cohort #2 (N=88)	Cohort #3 (N=368)
Number of HFH in prior year, Count (%)				
0	90 (19.7%)	7 (9.7%)	17 (19.3%)	73 (19.8%)
1	208 (45.6%)	48 (66.7%)	45 (51.1%)	163 (44.3%)
2	88 (19.3%)	9 (12.5%)	19 (21.6%)	69 (18.8%)
3	46 (10.1%)	5 (6.9%)	3 (3.4%)	43 (11.7%)
4	9 (2.0%)	1 (1.4%)	1 (1.1%)	8 (2.2%)
5	8 (1.8%)	2 (2.8%)	1 (1.1%)	7 (1.9%)
5+	7 (1.5%)	0 (0%)	2 (2.3%)	5 (1.4%)
Number of HFH in prior year, Mean (SD)	1.4 (1.3)	1.3 (1.0)	1.3 (1.2)	1.4 (1.3)
Number of HFH in prior year, Min	0	0	0	0
Number of HFH in prior year, Max	8	5	6	8
Other Cardiovascular History				
Hypertension, n (%)	403 (88.4%)	65 (90.3%)	74 (84.1%)	329 (89.4%)
Coronary artery disease, n (%)	269 (59.0%)	45 (62.5%)	57 (64.8%)	212 (57.6%)
Myocardial infarction, n (%)	118 (25.9%)	16 (22.2%)	21 (23.9%)	97 (26.4%)
Atrial fibrillation, n (%)	236 (51.8%)	39 (54.2%)	43 (48.9%)	193 (52.4%)
Transient ischemic attack, n (%)	23 (5.0%)	4 (5.6%)	3 (3.4%)	20 (5.4%)
Stroke, n (%)	48 (10.5%)	7 (9.7%)	7 (8.0%)	41 (11.1%)
Peripheral vascular disease, n (%)	61 (13.4%)	14 (19.4%)	10 (11.4%)	51 (13.9%)
Carotid artery disease, n (%)	33 (7.2%)	8 (11.1%)	4 (4.5%)	29 (7.9%)
Ventricular tachycardia, n (%)	88 (19.3%)	16 (22.2%)	19 (21.6%)	69 (18.8%)
Ventricular fibrillation, n (%)	18 (3.9%)	2 (2.8%)	4 (4.5%)	14 (3.8%)
Atrial flutter, n (%)	58 (12.7%)	9 (12.5%)	9 (10.2%)	49 (13.3%)
Implantable cardioverter defibrillator, n (%)	160 (35.1%)	21 (29.2%)	36 (40.9%)	124 (33.7%)
Cardiac resynchronization therapy, n (%)	82 (18.0%)	15 (20.8%)	15 (17.0%)	67 (18.2%)
Laboratory				
Estimated glomerular filtration rate [mL/min/1.73m ²], Mean (SD)	54.7 (18.7)	50.1 (19.7)	54.3 (18.2)	54.8 (18.8)
NT-proBNP [pg/mL], Mean (SD)	1731.4 (3012.8)	1768.8 (3809.4)	2061.0 (4401.6)	1655.1 (2590.4)

Characteristic	mITT (N=456)	Cohort #1 (N=72)	Cohort #2 (N=88)	Cohort #3 (N=368)
Hemodynamics (Right Heart Catheterization)				
Systolic pulmonary artery pressure (mmHg), Mean (SD)	43.3 (14.9)	40.9 (13.0)	43.9 (16.4)	43.2 (14.6)
Diastolic pulmonary artery pressure (mmHg), Mean (SD)	18.8 (7.9)	18.4 (6.4)	19.6 (8.9)	18.6 (7.7)
Mean pulmonary artery pressure (mmHg), Mean (SD)	28.2 (10.1)	26.7 (8.9)	29.1 (11.6)	28.0 (9.7)
Right atrial pressure (mmHg), Mean (SD)	9.7 (6.7)	9.0 (4.6)	10.1 (5.7)	9.6 (7.0)
Pulmonary capillary wedge pressure (mmHg), Mean (SD)	16.5 (8.7)	15.3 (6.8)	16.9 (9.9)	16.4 (8.3)
Cardiac output (L/min), Mean (SD)	5.3 (3.2)	5.6 (3.3)	5.0 (1.3)	5.4 (3.5)
Cardiac index (L/min/m ²), Mean (SD)	2.4 (0.6)	2.7 (1.4)	2.3 (0.5)	2.4 (0.6)
Vital Signs				
Systolic blood pressure, Mean (SD)	121.8 (19.1)	116.6 (18.7)	120.6 (17.6)	122.0 (19.5)
Diastolic blood pressure, Mean (SD)	72.9 (12.6)	67.9 (11.3)	72.7 (11.8)	73.0 (12.8)
Heart rate, Mean (SD)	77.2 (14.1)	77.7 (14.1)	77.6 (14.4)	77.1 (14.1)
Blood oxygen saturation, Mean (SD)	95.8 (2.8)	96.1 (2.5)	95.9 (2.9)	95.8 (2.8)
Heart Failure Medications				
Agents acting on the renin-angiotensin system, n (%)	310 (68.0%)	46 (63.9%)	61 (69.3%)	249 (67.7%)
Angiotensin receptor-neprilysin inhibitor, n (%)	199 (43.6%)	23 (31.9%)	36 (40.9%)	163 (44.3%)
Angiotensin II receptor blocker, n (%)	84 (18.4%)	21 (29.2%)	16 (18.2%)	68 (18.5%)
Angiotensin-converting enzyme inhibitor, n (%)	32 (7.0%)	4 (5.6%)	12 (13.6%)	20 (5.4%)
Beta blocker, n (%)	395 (86.6%)	61 (84.7%)	75 (85.2%)	320 (87.0%)
Diuretic, n (%)	454 (99.6%)	72 (100.0%)	88 (100.0%)	366 (99.5%)
Loop diuretic, n (%)	444 (97.4%)	72 (100.0%)	85 (96.6%)	359 (97.6%)
Thiazide diuretic, n (%)	2 (0.4%)	2 (2.8%)	2 (2.3%)	0 (0%)
Aldosterone antagonist, n (%)	310 (68.0%)	47 (65.3%)	54 (61.4%)	256 (69.6%)
Sodium-glucose transport protein 2 inhibitor, n (%)	265 (58.1%)	21 (29.2%)	29 (33.0%)	236 (64.1%)
Hydralazine, n (%)	35 (7.7%)	5 (6.9%)	6 (6.8%)	29 (7.9%)
Nitrates, n (%)	83 (18.2%)	12 (16.7%)	13 (14.8%)	70 (19.0%)

Characteristic	mITT (N=456)	Cohort #1 (N=72)	Cohort #2 (N=88)	Cohort #3 (N=368)
Functional Capacity & Quality of Life				
New York heart association functional class III, n (%)	456 (100.0%)	71 (98.6%)	88 (100.0%)	367 (99.7%)
Kansas City cardiomyopathy questionnaire overall summary score (points), Mean (SD)	52.8 (22.8)	49.7 (23.8)	52.4 (22.7)	52.8 (22.9)
Six-minute walk test (m), Mean (SD)	259.5 (121.1)	281.5 (133.6)	270.7 (120.7)	256.9 (121.2)
Enrollment Type				
Enrollment Type: HFH, n (%)	150 (32.9%)	31 (43.1%)	37 (42.0%)	113 (30.7%)
Enrollment Type: NT-proBNP, n (%)	89 (19.5%)	6 (8.3%)	16 (18.2%)	73 (19.8%)
Enrollment Type: HFH and NT-proBNP, n (%)	216 (47.4%)	34 (47.2%)	34 (38.6%)	182 (49.5%)
Enrollment Type: Does Not Meet Criteria, n (%)	1 (0.2%)	1 (1.4%)	1 (1.1%)	0 (0%)
LVEF = Left Ventricular Ejection Fraction, HF = Heart Failure, HFH = Heart Failure Hospitalization				

17.7 Safety and Effectiveness Results

17.7.1 Safety Results

Primary Safety Results

Primary Safety Endpoints: Main Analysis

The analysis of safety was based on the Intention to Treat population (ITT) from Cohort #2 and Cohort #3, comprising 493 patients available for the 6-month evaluation. The key safety outcomes for this study are presented below in Tables 3 to 5. Adverse effects are reported in Tables 6 to 7.

First Primary Safety Endpoint

The first primary safety endpoint describes freedom from a Device/System Related Complications (DSRC) through 6 months and was tested against the null rate of 90%. In the ITT population a total of four (4) DSRCs occurred. The probability of being free from a DSRC at 6 months post implant procedure was 99.2% [95% CI: 97.9%, 99.7%]. The lower bound of the confidence interval, based on the Kaplan-Meier (KM) method, is higher than the null rate of 90%. (Table 3 and plot Figure 4).

The first primary safety endpoint was met.

None of the DSRCs resulted in permanent subject impairment or death and all subjects recovered without sequelae. Clinical details of all DSRCs (four (4) events in ITT and one (1) event in Cohort#1) are shown in Table 4.

Table 3: PROACTIVE-HF / ETX-HFS-PA-03: Freedom From Device / System Related Complications – Results Through 6 months for ITT Population

Item	Result	ITT (N=493)
Subject with any DSRC	n (%)	4 (0.8%)
Censored	n (%)	489 (99.2%)
Subjects completed 6 months and without any DSRC	n (%)	439 (89.0%)
Subjects withdrew prior to 6 months and without any DSRC	n (%)	50 (10.1%)
Time to first DSRC (days)**		
25% percentile [95% CI]	181.0	
Median [95% CI]	181.0	
75% percentile [95% CI]	181.0	
Minimum	0.0	
Maximum	181.0	
Probability of being free from DSRC	rate [95% CI]	99.2 [97.9 - 99.7]

** With a very small proportion of subjects who have experienced an event, the median time is likely to be shorter than the actual time to event in the population; based on the limited number of events observed there is an underestimate of the true underlying time to event.

Probability of being free from DSRC at 6 months was estimated using the Kaplan-Meier method.

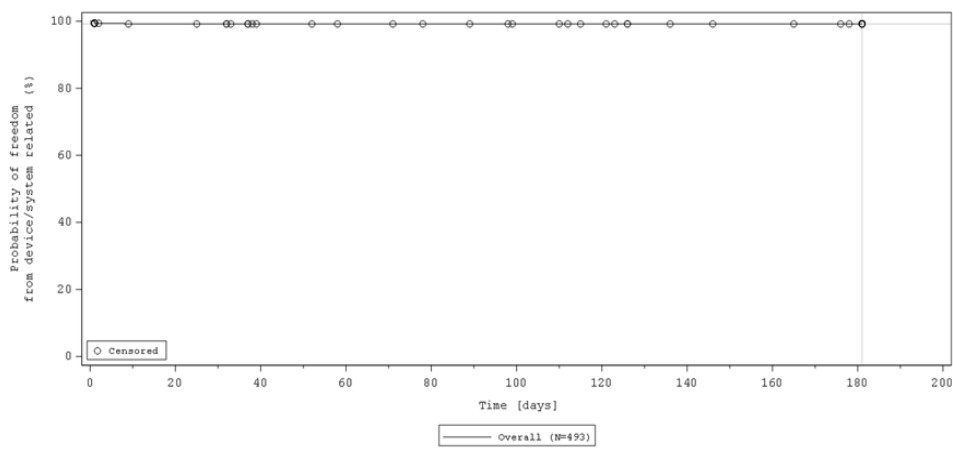

Figure 4: First Primary Safety Endpoint Analysis: Freedom From Device / System Related Complications Kaplan-Meier Plot*

* In case of event, time to event = [(Date of event – date of Implant visit) + 1]; In case of no event, time to event = [(Date of last available date – date of Implant visit) + 1], this data will be censored.

Table 4: Summary of DSRCs as Adjudicated by the CEC (ITT Population and Cohort #1)

Event Description and Term	N (%)	Outcome
Further Migration of the Cordella Sensor / Device Dislocation	1 (0.2%)	Recovered
Right internal jugular blood vessel complications secondary to device insertion attempt / Procedure Complication	1 (0.2%)	Recovered
Implant Device Complication/ Complication associated with device	1 (0.2%)	Recovered
Device breakage/ Pressure sensor fracture	1 (0.2%)	Recovered
Total Subjects Experiencing a DSRC in ITT population	4 (0.8%)	
Event Description and Term	N (%)	Outcome
LV-Lead dislodgement/ Lead Dislodgement	1 (1.4%)	Recovered
Total Subjects Experiencing a DSRC in Cohort #1	1 (1.4%)	

Second Primary Safety Endpoint

The second primary safety endpoint describes freedom from Pressure Sensor Failure (PSF) through 6 Months, which was tested against the null rate of 95%. With one (1) event the Freedom from Pressure Sensor Failure rate was 99.8% (Table 5). The probability of being free from a Pressure Sensor Failure event at 6 months post implant procedure was 99.8 % [95% CI: 98.6%, 100%]. The lower bound of the confidence interval, based on the KM method (Figure 5), is higher than the null rate of 95%.

The second primary safety endpoint was met.

The event of PSF is ongoing with the device implanted and without any further related events.

Table 5: Second Primary Safety Endpoint Analysis: Freedom from Pressure Sensor Failure

Item	Result	ITT (N=493)
Subject with any PSF	n (%)	1 (0.2%)
Censored	n (%)	492 (99.8%)
Subjects completed 6 months and without any PSF	n (%)	440 (89.2%)
Subjects withdrew prior to 6 months and without any PSF	n (%)	52 (10.5%)
Time to first PSF (days)		
25% percentile [95% CI]	181.0	
Median [95% CI]	181.0	
75% percentile [95% CI]	181.0	
Minimum	0.0	
Maximum	181.0	
Probability of being free from PSF	rate [95% CI]	0.998 [0.986 - 1.0]

Probability of being free from PSF at 6 months was estimated using the Kaplan-Meier method

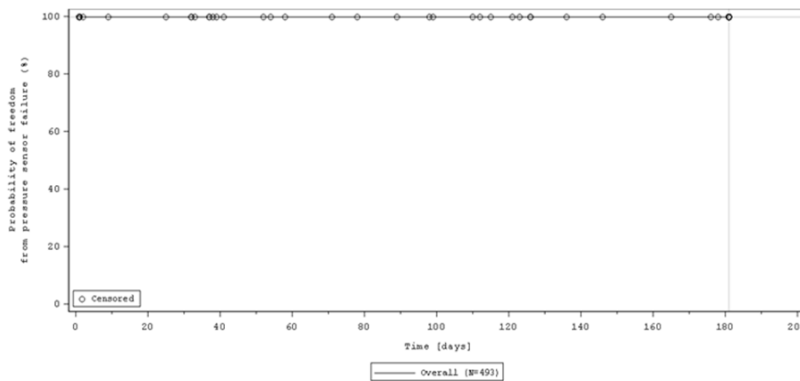

Figure 5: Second Primary Safety Endpoint Analysis: Freedom from Pressure Sensor Failure Kaplan-Meier Plot*

* In case of event, time to event = [(Date of event - date of Implant visit) + 1]; In case of no event, time to event = [(Date of last available date - date of Implant visit) + 1], this data will be censored.

Secondary Safety Results

Secondary safety endpoints were based on mITT population for (1) Pressure Sensor Failure rate throughout the study, and ITT population for (2) frequency of site reported SAEs throughout the study and (3) frequency of CEC adjudicated implant procedure and procedure-related AEs and SAEs.

Pressure Sensor Failure Rate throughout the Study

Up to the 6-month FU visit only (1) Pressure Sensor Failure has been reported.

Frequency of Serious Adverse Events (SAEs) throughout the Study

Table 6 presents a summary of serious adverse events as reported by investigators. There were no unanticipated adverse device effects (UADEs).

Table 6: Predefined Serious Adverse Events by Category Through 6 Months for ITT and Cohort #1 Populations

Item	Result	ITT (N=493)	Cohort #1 (N=72)	ITT + Cohort 1 (N=565)	Cohort 1 vs ITT p-value
Subjects with at least one predefined SAE	n (%) n*	196 (39.8%) 425.0	31 (43.1%) 85.0	227 (40.2%) 510.0	0.5938
Heart Failure	n (%) n*	79 (16.0%) 100.0	16 (22.2%) 31.0	95 (16.8%) 131.0	0.189
ED Visit	n (%) n*	4 (0.8%) 4.0	0 (0%)	4 (0.7%) 4.0	0.4431
Hospitalization	n (%) n*	72 (14.6%) 90.0	16 (22.2%) 31.0	88 (15.6%) 121.0	0.0959
Urgent, Unscheduled Outpatient Office/ Practice	n (%) n*	2 (0.4%) 2.0	0 (0%)	2 (0.4%) 2.0	0.5882
Acute Kidney Injury (AKIN)	n (%) n*	22 (4.5%) 26.0	7 (9.7%) 8.0	29 (5.1%) 34.0	0.0589
Bleeding	n (%) n*	6 (1.2%) 6.0	4 (5.6%) 4.0	10 (1.8%) 10.0	0.0091
Conduction Disturbances and Arrhythmias	n (%) n*	28 (5.7%) 35.0	4 (5.6%) 4.0	32 (5.7%) 39.0	0.9661
Hemoptysis	n (%) n*	12 (2.4%) 13.0	1 (1.4%) 1.0	13 (2.3%) 14.0	0.5806
Myocardial Infarction (MI)	n (%) n*	3 (0.6%) 3.0	1 (1.4%) 1.0	4 (0.7%) 4.0	0.4607
Pulmonary Embolism	n (%) n*	6 (1.2%) 7.0	0 (0%)	6 (1.1%) 7.0	0.3467
Pulmonary Occlusion	n (%) n*	0 (0%)	0 (0%)	0 (0%)	NE
Renal Dysfunction	n (%) n*	8 (1.6%) 9.0	1 (1.4%) 1.0	9 (1.6%) 10.0	0.8823
Stroke and Trans Ischemic Attach (TIA)	n (%) n*	0 (0%)	1 (1.4%) 1.0	1 (0.2%) 1.0	0.0088
Vascular Access Site and Access-Related Complications	n (%) n*	4 (0.8%) 4.0	2 (2.8%) 2.0	6 (1.1%) 6.0	0.1284
Vessel Trauma	n (%) n*	4 (0.8%) 4.0	0 (0%)	4 (0.7%) 4.0	0.4431
Other	n (%) n*	123 (24.9%) 215.0	17 (23.6%) 30.0	140 (24.8%) 245.0	0.8059
Item	Result	ITT (N=493)	Cohort #1 (N=72)	ITT + Cohort 1 (N=565)	Cohort 1 vs ITT p-value
Subjects with at least one OTHER SAE	n (%) n*	123 (24.9%) 215.0	17 (23.6%) 30.0	140 (24.8%) 245.0	0.8059
Blood and lymphatic system disorders	n (%) n*	4 (0.8%) 6.0	0 (0%)	4 (0.7%) 6.0	0.4431
Cardiac disorders	n (%) n*	6 (1.2%) 7.0	1 (1.4%) 2.0	7 (1.2%) 9.0	0.902
Ear and labyrinth disorders	n (%) n*	1 (0.2%) 1.0	0 (0%)	1 (0.2%) 1.0	0.7021
Gastrointestinal disorders	n (%) n*	12 (2.4%) 14.0	1 (1.4%) 1.0	13 (2.3%) 15.0	0.5806
General disorders and administration site conditions	n (%) n*	8 (1.6%) 9.0	2 (2.8%) 4.0	10 (1.8%) 13.0	0.4875
Hepatobiliary disorders	n (%) n*	6 (1.2%) 7.0	0 (0%)	6 (1.1%) 7.0	0.3467
Immune system disorders	n (%) n*	1 (0.2%) 1.0	0 (0%)	1 (0.2%) 1.0	0.7021
Infections and infestations	n (%) n*	46 (9.3%) 63.0	9 (12.5%) 11.0	55 (9.7%) 74.0	0.3967
Injury, poisoning and procedural complications	n (%) n*	10 (2.0%) 11.0	0 (0%)	10 (1.8%) 11.0	0.2227
Investigations	n (%) n*	2 (0.4%) 2.0	0 (0%)	2 (0.4%) 2.0	0.5882
Metabolism and nutrition disorders	n (%) n*	9 (1.8%) 9.0	3 (4.2%) 4.0	12 (2.1%) 13.0	0.1981
Musculoskeletal and connective tissue disorders	n (%) n*	4 (0.8%) 4.0	0 (0%)	4 (0.7%) 4.0	0.4431
Neoplasms benign, malignant and unspecified (incl cysts and polyps)	n (%) n*	1 (0.2%) 1.0	0 (0%)	1 (0.2%) 1.0	0.7021
Nervous system disorders	n (%) n*	13 (2.6%) 16.0	1 (1.4%) 1.0	14 (2.5%) 17.0	0.5245
Product issues	n (%) n*	6 (1.2%) 6.0	2 (2.8%) 2.0	8 (1.4%) 8.0	0.2951
Psychiatric disorders	n (%) n*	2 (0.4%) 2.0	1 (1.4%) 1.0	3 (0.5%) 3.0	0.2836
Renal and urinary disorders	n (%) n*	2 (0.4%) 2.0	0 (0%)	2 (0.4%) 2.0	0.5882
Respiratory, thoracic and mediastinal disorders	n (%) n*	25 (5.1%) 32.0	3 (4.2%) 4.0	28 (5.0%) 36.0	0.7412
Skin and subcutaneous tissue disorders	n (%) n*	4 (0.8%) 4.0	0 (0%)	4 (0.7%) 4.0	0.4431
Surgical and medical procedures	n (%) n*	1 (0.2%) 1.0	0 (0%)	1 (0.2%) 1.0	0.7021
Vascular disorders	n (%) n*	16 (3.2%) 17.0	0 (0%)	16 (2.8%) 17.0	0.121
Item	Result	ITT (N=493)	Cohort #1 (N=72)	ITT + Cohort 1 (N=565)	Cohort 1 vs ITT p-value
Subjects with at least one Unanticipated SAE	n (%) n*	151 (30.6%) 297.0	24 (33.3%) 45.0	175 (31.0%) 342.0	0.6429
Blood and lymphatic system disorders	n (%) n*	4 (0.8%) 5.0	0 (0%)	4 (0.7%) 5.0	0.4431
Cardiac disorders	n (%) n*	59 (12.0%) 82.0	10 (13.9%) 13.0	69 (12.2%) 95.0	0.6419
Ear and labyrinth disorders	n (%) n*	1 (0.2%) 1.0	0 (0%)	1 (0.2%) 1.0	0.7021
Gastrointestinal disorders	n (%) n*	13 (2.6%) 14.0	2 (2.8%) 3.0	15 (2.7%) 17.0	0.9446
General disorders and administration site conditions	n (%) n*	7 (1.4%) 7.0	2 (2.8%) 4.0	9 (1.6%) 11.0	0.39
Hepatobiliary disorders	n (%) n*	4 (0.8%) 5.0	0 (0%)	4 (0.7%) 5.0	0.4431
Immune system disorders	n (%) n*	1 (0.2%) 1.0	0 (0%)	1 (0.2%) 1.0	0.7021
Infections and infestations	n (%) n*	41 (8.3%) 51.0	8 (11.1%) 9.0	49 (8.7%) 60.0	0.4312
Injury, poisoning and procedural complications	n (%) n*	12 (2.4%) 12.0	2 (2.8%) 2.0	14 (2.5%) 14.0	0.8609
Investigations	n (%) n*	1 (0.2%) 1.0	0 (0%)	1 (0.2%) 1.0	0.7021
Metabolism and nutrition disorders	n (%) n*	14 (2.8%) 15.0	2 (2.8%) 2.0	16 (2.8%) 17.0	0.9764
Musculoskeletal and connective tissue disorders	n (%) n*	3 (0.6%) 3.0	1 (1.4%) 1.0	4 (0.7%) 4.0	0.4607
Nervous system disorders	n (%) n*	11 (2.2%) 14.0	3 (4.2%) 3.0	14 (2.5%) 17.0	0.3237
Product issues	n (%) n*	3 (0.6%) 4.0	3 (4.2%) 3.0	6 (1.1%) 7.0	0.0059
Psychiatric disorders	n (%) n*	2 (0.4%) 2.0	1 (1.4%) 1.0	3 (0.5%) 3.0	0.2836
Renal and urinary disorders	n (%) n*	18 (3.7%) 23.0	2 (2.8%) 2.0	20 (3.5%) 25.0	0.7079
Respiratory, thoracic and mediastinal disorders	n (%) n*	30 (6.1%) 37.0	1 (1.4%) 1.0	31 (5.5%) 38.0	0.1021
Skin and subcutaneous tissue disorders	n (%) n*	4 (0.8%) 4.0	0 (0%)	4 (0.7%) 4.0	0.4431
Surgical and medical procedures	n (%) n*	2 (0.4%) 2.0	0 (0%)	2 (0.4%) 2.0	0.5882
Vascular disorders	n (%) n*	13 (2.6%) 14.0	1 (1.4%) 1.0	14 (2.5%) 15.0	0.5245

Of note, with an event rate of 3.0% for all-cause hemoptysis, the event rate of this safety endpoint in the early experience with this new device is numerically higher than prior studies completed to date with similar PAP-measuring devices, such as in CHAMPION (0.2%), GUIDE-HF (0.3%) and MONITOR-HF (2.3%).

Frequency of Implant Procedure and Procedure-Related Adverse Events and Serious Adverse Events

Table 7 presents a summary of CEC adjudicated implant procedure and/or Cordella PA Sensor System related AEs and SAEs.

Table 7: Summary of CEC adjudicated Non-DSRC related AEs or SAEs

Item	Result n=Number of subjects (%) n*=Number of events	ITT (N=493)
Subjects with at least one predefined AE or SAE with study device or implant procedure relationship	n (%) n*	37* (7.5%) 39
Bleeding	n (%) n*	3 (0.6%) 3
Conduction Disturbances and Arrhythmias	n (%) n*	4 (0.8%) 4
Heart Failure	n (%) n*	2 (0.4%) 2
Hemoptysis	n (%) n*	15 (3.0%) 16
Pulmonary Embolism	n (%) n*	1 (0.2%) 1
Vascular Access Site and Access-Related Complications	n (%) n*	12 (2.4%) 13
Other	n (%) n*	16 (3.2%) 16
TOTAL	n (%) n*	52 (10.5%) 54

*Subjects may overlap in Predefined AE/SAE Categories and Category Other

17.7.2 Effectiveness Results

The analysis of effectiveness was based on the 456 evaluable patients at the sixth month time point. Key effectiveness outcomes are presented in Tables 8 to 9.

Primary Effectiveness Results

Primary Efficacy Endpoint: Main Analysis

The historical composite event rates of HF hospitalization and all-cause mortality obtained from CardioMEMS literature and an internally derived meta-analysis for patients managed with PAP-guided HF management ranged from 0.31-0.44 events per patient 6-month and the historical composite event rates for the control arm patients ranged from 0.39-0.51.

The primary endpoint was based on all mITT subjects. The 6-month incidence of HF related hospitalizations or all-cause mortality was 0.1589 [95% CI: 0.1200, 0.2106] events per patient 6-month. The observed rate of 0.1589 was significantly less than PG (0.1589 vs 0.43; p<0.0001). Given that the upper confidence bound of the observed event rate was less than PG (0.1589 vs 0.43), the observed rate was significantly lower than PG, and the observed rate was less than 0.37, all criteria for the primary efficacy were satisfied and the primary efficacy endpoint was met.

Of note, while the PROACTIVE-HF aimed to enroll NYHA class III HF patients, the final event rate for the primary effectiveness endpoint (0.1589) was numerically much lower than the average event rate derived from published results from clinically relevant, contemporary studies of NYHA class III HF subjects (as evidenced by an historical performance goal originally set at 0.43). While supportive of the overall benefit of the device, the benefit profile was not compared against concurrent standard of care subjects which should be taken into account when considering this device for a patient until additional data is available.

The primary efficacy endpoint summary statistics are shown in Table 8.

Table 8: Primary Endpoint Analysis and Components

Overall Primary Efficacy Endpoint Analysis and Components	Result	mITT (N=456)
6-month incidence of HF hospitalization or all-cause mortality	Event rate*	0.1589
	[95% CI]*	0.1200-0.2106
	p-value	<0.0001**
6-month incidence of HF hospitalization	Event Rate *	0.1334
	[95% CI]*	0.0989-0.1798
6-month incidence of all-cause mortality	Event Rate*	0.0221
	[95% CI]*	0.0119-0.0411
Number of HF hospitalization	n	60
Number of all-cause mortality	n	10
Total number of HF hospitalization or all-cause mortalities	n	70
HF hospitalization or all-cause mortalities subject event rate	n	456
	mean (SD)	0.1793 (0.5403)
	median	0.0
	min	0.0
	max	3.46
	missing (%)	0 (0%)
HF hospitalization or all-cause mortalities number of events per subject	n	456
	mean (SD)	0.15 (0.45)
	median	0.0
	min	0
	max	3
	missing (%)	0 (0%)
* Event rates with 95% confidence intervals were calculated using a negative binomial model		
**A one-sided p-value < 0.025 indicates that the 6 month incidence of HF hospitalizations or all-cause mortality < 0.43		
HF = Heart Failure Hospitalization. CI = Confidence Interval		

Primary Efficacy Endpoint: Stratified by Cohort Number

The main analysis was repeated on the individual cohort numbers and interpretation of p-values is done in a descriptive manner only. In the Cohort #1 population, the 6-month incidence of HF related hospitalizations or all-cause mortality was 0.3106 [95% CI: 0.1341, 0.7195] events per patient 6-month. The observed rate was not significantly less than PG (0.3106 vs 0.43; p=0.2214).

Comparison of the 6-month incidence of HF hospitalization or all-cause mortality event rates between subgroups was done with a negative binomial model. An alpha level of 0.15 is used for subgroup comparisons to balance type I and II error concerns given the study is not prospectively powered for such statistical hypothesis tests. The subgroup comparisons are generally considered to be exploratory and hypothesis generating. There is no adjustment for multiple comparisons.

The 6-month incidence of HF related hospitalizations or all-cause mortality was significantly different between Cohort #1 and the mITT population (Cohort #2 plus Cohort #3) (0.3106 vs. 0.1589, p=0.0858). Differences between Cohort #2 and Cohort #3 event rates (0.1557 vs. 0.1595, p=0.8979) were not significant. The primary efficacy endpoint summary statistics for Cohort #1, Cohort #2, and Cohort #3 are shown in Table 9.

Table 9: Primary Endpoint Analysis and Components Stratified by Cohort Number

Efficacy Endpoint Analysis and Components	Result	Cohort #1 (N=72)	Cohort #2 (N=88)	Cohort #3 (N=368)
6-month incidence of HF hospitalization or all-cause mortality	Event rate*	0.3106	0.1557	0.1595
	[95% CI]*	0.1341-0.7195	0.0731-0.3313	0.1180-0.2156
	p-value	0.2214	0.0042**	<0.0001**
6-month incidence of HF hospitalization	Event Rate*	0.269	0.1279	0.1347
	[95% CI]*	0.1234-0.5867	0.0590-0.2770	0.0975-0.1861
6-month incidence of all-cause mortality	Event Rate*	0.0279	0.023	0.0219
	[95% CI]*	0.0070-0.1114	0.0057-0.0919	0.0110-0.0438
Number of HF hospitalization	n	18	11	49
Number of all-cause mortality	n	2	2	8
Total number of HF hospitalization or all-cause mortalities	n	20	13	57
HF hospitalization or all-cause mortalities subject event rate	n	72	88	368
	mean (SD)	0.3351 (1.1326)	0.1643 (0.5516)	0.1829 (0.5383)
	median	0	0	0
	min	0	0	0
	max	6.84	3.03	3.46
	missing (%)	0 (0%)	0 (0%)	0 (0%)
HF hospitalization or all-cause mortalities number of events per subject	n	72	88	368
	mean (SD)	0.28 (0.86)	0.15 (0.49)	0.15 (0.44)
	median	0	0	0
	min	0	0	0
	max	5	3	3
	missing (%)	0 (0%)	0 (0%)	0 (0%)
Cohort #1 vs. mITT (Cohort #2 & Cohort #3) Event Rate p-value			0.0859†	
Cohort #1 vs. Cohort #2 Event Rate p-value			0.2378†	
Cohort #2 vs. Cohort #3 Event Rate p-value			0.8979†	
*Event rates with 95% confidence intervals were calculated using a negative binomial model				
**A one-sided p-value < 0.025 indicates that the 6 month incidence of HF hospitalizations or all-cause mortality < 0.43				
† alpha =0.15 for subgroup comparisons				
HF = Heart Failure Hospitalization, CI = Confidence Interval				

Secondary Effectiveness Results

All secondary efficacy endpoints were based on the mITT population and are applicable to 6-month follow-up. At 12-month follow-up, key secondary efficacy endpoints covered include 1) the incidence of HF hospitalization and all-cause mortality at 12 months, 2) The number of HF hospitalizations at 12 months post-implant compared to the number of HF hospitalizations in the 12 months prior to implant, 3) Comparison of the number of HF Hospitalizations or Emergency Department/ Hospital Outpatient IV diuretic visits of Cohort #1 and Cohort #2 + Cohort #3 at 12 months post implant, 4) change of N-terminal pro B-type Natriuretic Peptide (NT-proBNP) from Baseline through 12 months, 5) heart failure hospitalization or HF Emergency Department / Hospital Outpatient IV diuretic visits at 12 months, and 6) Change in pulmonary artery pressure from baseline through 12 months. 6-month results are presented below.

- The number of HF hospitalizations per subject at 6 months post-implant was significantly fewer than the number of HF hospitalizations per subject in the 6 months prior to implant in the mITT (0.6 ± 0.7 vs 0.1 ± 0.4 ; $p < 0.0001$).
- For every HF hospitalizations or emergency department/ hospital outpatient IV diuretic visit event in Cohort #2 and Cohort #3 there were 1.4725 events in Cohort #1. The rate of events in Cohort #1 compared to the rate of events in Cohort #2 and Cohort #3 (0.2508 vs 0.1703 , $p = 0.0697$) was significant (alpha level of 0.15).
- Mean NT-proBNP decreased from Screening to 6 months, however the change was not significant (1731.4 ± 3012.8 vs 1632.5 ± 2742.4 pg/ml, $p = 0.0628$).
- In the mITT population, 63 (13.8%) subjects had at least one of the combined outcomes of first and recurrent HF hospitalizations, emergency department/ hospital outpatient IV diuretic visits, and all-cause mortality with an event rate of 0.1925 [95% CI: 0.156, 0.2375]. These were primarily made up of first and recurrent HF hospitalization (N=60, 84% of total events), followed by emergency department / hospital outpatient IV diuretic visits (N = 17, 19.5% of total events) and all-cause mortality (N=10, 11.5% of total events).
- In the mITT population, 56 (12.3%) subjects had at least one of the combined outcomes of HF hospitalization of HF emergency/ outpatient IV diuretic visits with an event rate of 0.1703 [95% CI: 0.1362, 0.213]. These were primarily made up of HF hospitalization (N=60, 78% of total events), followed by emergency department / hospital outpatient IV diuretic visits (N = 17, 22% of total events).
- In the mITT population, there were 10 all-cause deaths, 6 of which were cardiac related. All-cause mortality event rate was 0.0221 [95% CI: 0.0119, 0.0411] and cardiac mortality event rate was 0.0133 [95% CI: 0.006, 0.0295].
- Patients in the mITT population spent an average 172.0 ± 27.2 days alive and out of hospital.
- In the mITT population, 14 (3.1%) subjects had 17 outpatient IV diuretic visits with an event rate of 0.0376 [95% CI: 0.0234, 0.0605]. These were primarily made of hospital outpatient IV diuretic visits (N=10, 59% of total events) followed by HF emergency department IV diuretic visits (N=7, 41% of total events).
- For the mITT population, 234 (51.3%) subjects had a HF related medication change from implant to Month 1, 227 (49.8%) subjects had a HF related medication change from Month 1 to Month 3, and 260 (57.0%) had a HF related medication change from Month 3 to Month 6.
- Overall, the device successfully transmitted PAP data in 67651 out of 68232 days of data collection (>99%).

Change in PAP

Mean pulmonary artery pressure (mPAP) is summarized at all study visits by 'Above Target range', 'Within/Below Target range', and 'Overall' for subjects with a baseline mPAP. Target range is seated trend mPAP 5-20 mmHg.

Seated trend mPAP and supine mPAP are external data collected by Endotronix, as measured by the Cordella System, and transmitted by the patients from home. Baseline is defined as the first trend seated mPAP transmitted from the patient within 14 days of the Implant Visit. V3 – Month 1 is defined as the last seated trend within 7 days prior to the visit, V4 – Month 3 is defined as the last seated trend within 7 days prior to the visit, and V5 – Month 6 is defined as the last seated trend within 14 days prior to and 14 days after the visit. Figure 6 shows the baseline distribution of RHC Supine Mean PA Pressure.

Figure 6: Histogram of Baseline Right Heart Catheterization Supine Mean Pulmonary Artery Pressure

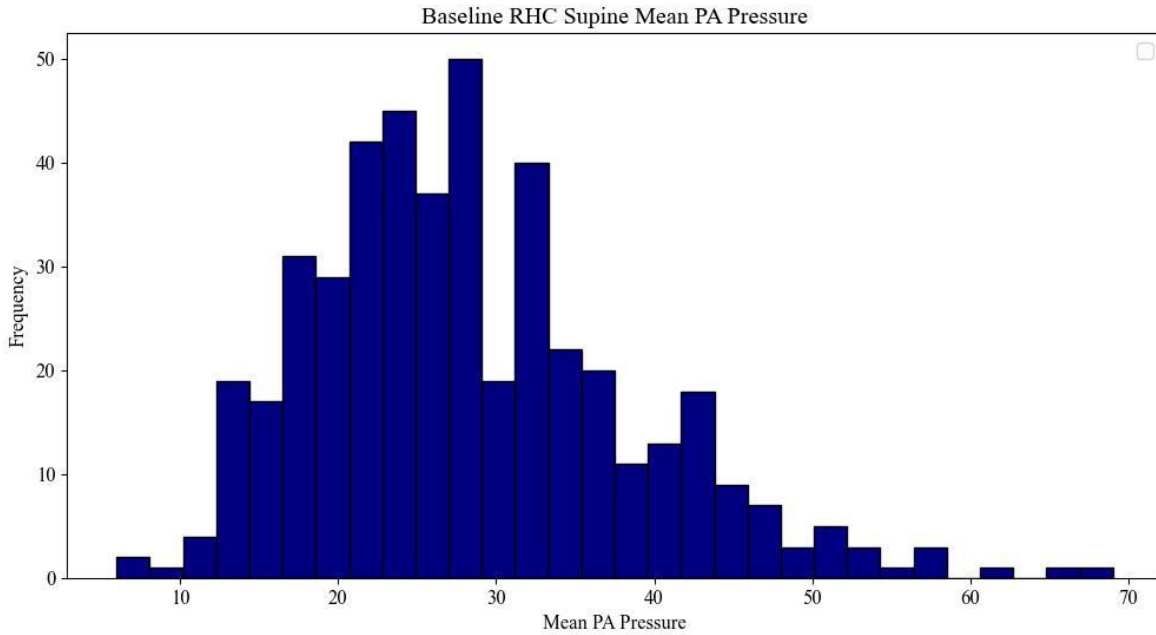

In the overall mITT population, the seated trend mPAP increased significantly over 6 months (20.2 ± 10.3 vs. 21.4 ± 9.3 mmHg, $p=0.002$), as shown in Figure 7.

Figure 7: Average Trend Seated Mean Pulmonary Artery Pressure in the mITT Population

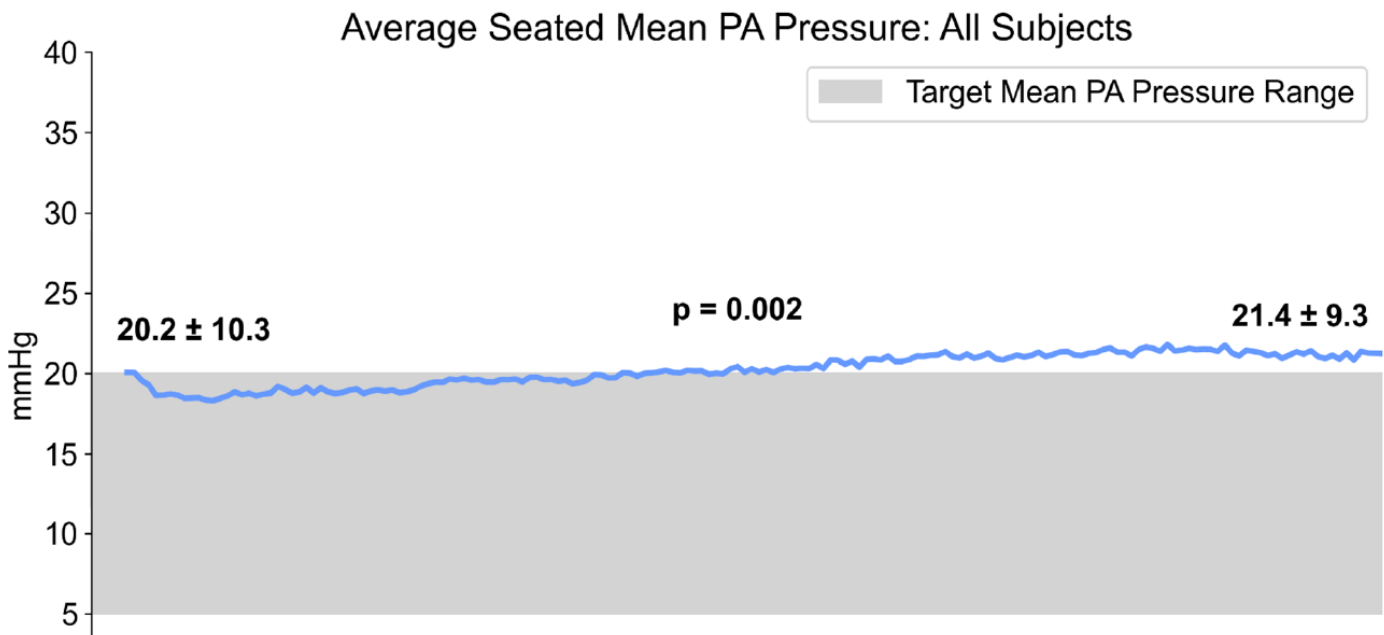

In the Above Target population, the seated trend mPAP decreased significantly over 6 months (29.2 ± 7.7 vs. 26.8 ± 9.2 mmHg, $p=0.0006$). In the Below/Within Target population, the seated trend mPAP increased significantly over 6 months (12.8 ± 4.9 vs. 17.0 ± 6.8 mmHg, $p<0.0001$). Summary statistics for the mITT population are shown in Table 10.

Table 10: Change in Seated Trend mPAP from Baseline through 6 months for mITT Population

Category	Time	Result	mITT (N=456)	Above Target* (N = 206)	Below/Within Target* (N = 247)
Seated Trend mPAP (mmHg)	Baseline	n	437	197	240
		Missing, n (%)	19 (4.0%)	9 (4.0%)	7 (3.0%)
		mean (SD)	20.2 (10.3)	29.2 (7.7)	12.8 (4.9)
		median	19.12	27.43	13.7
	V3 - Month 1	n	432	199	233
		Missing, n (%)	24 (5.0%)	7 (3.0%)	14 (6.0%)
		mean (SD)	18.9 (11.5)	26.0 (8.8)	12.9 (10.0)
		median	17.62	25.22	12.5
	V4 - Month 3	n	426	194	232
		Missing, n (%)	30 (7.0%)	12 (6.0%)	15 (6.0%)
		mean (SD)	20.3 (9.6)	26.4 (9.2)	15.2 (6.6)
		median	18.83	25.84	15.07
	V5 - Month 6	n	388	171	210
		Missing, n (%)	68 (15%)	35 (17%)	37 (15%)
		mean (SD)	21.4 (9.3)	26.8 (9.2)	17.0 (6.8)
		median	20.4	16.2	17.3
Mean Implant Visit vs. Mean V5 - Month 6		p-value	0.0016	0.0006†	<0.0001†

mPAP = mean pulmonary artery pressure; * Target = seated trend mPAP 5-20mmHg as first transmitted from home. Baseline cut-off is 14 days from implant; †Repeated-measures-test

Change in Medication

Pulmonary artery pressure before and after changes in medication are also provided for the mITT cohort in Table 11. For the mITT cohort, an average increase in pulmonary artery pressures over 2-3 weeks preceded a medication increase. Following the medication increase, there was an average decrease in pulmonary artery pressures over 1-3 weeks for most medication classes.

Table 11: Mean and Standard Deviation of Trend Mean Seated Pulmonary Artery Pressures by Day of Dosage Increases of Various Medication Classes in the mITT Population (N=456)

Med Class	Number Patients	Number Increases	21 Days Before	14 Days Before	7 Days Before	Day Before	3 Days After	7 Days After	14 days After	21 Days After
Diuretic	276	1119	23.0 (8.6)	23.4 (8.5)	23.8 (8.7)	24.3 (8.7)	24.5 (8.6)	23.9 (8.6)	23.7 (8.6)	23.6 (8.4)
RASI	90	134	20.7 (10.5)	20.8 (10.0)	21.1 (10.1)	21.6 (10.0)	21.5 (9.9)	21.1 (9.5)	20.7 (9.0)	21.0 (9.2)
Beta Blocker	88	123	17.9 (9.0)	18.6 (8.7)	18.7 (9.1)	19.4 (8.8)	19.3 (8.6)	19.7 (9.1)	19.8 (9.2)	19.9 (8.8)
SGLT2-I	45	55	22.5 (8.7)	22.7 (9.0)	22.6 (9.1)	22.9 (8.2)	22.9 (7.8)	22.7 (8.1)	22.4 (8.5)	22.2 (8.6)
MRA	90	118	21.5 (8.6)	21.0 (8.5)	22.1 (10.0)	22.3 (9.5)	22.2 (9.1)	22.0 (9.4)	21.8 (9.2)	21.2 (8.6)
Nitrate	25	38	20.4 (11.2)	20.1 (10.7)	21.1 (10.3)	20.9 (9.6)	20.7 (9.5)	20.5 (9.7)	20.7 (9.8)	19.3 (9.6)
HHC	21	36	19.7 (9.2)	20.8 (8.7)	21.5 (10.2)	22.0 (10.2)	22.0 (9.5)	21.4 (10.2)	21.8 (11.1)	22.0 (12.4)

RASI = renin-angiotensin system inhibitor; SGLT2-I = sodium-glucose cotransporter 2 inhibitor; MRA = Minerlocor-ticoid receptor antagonist; HHC = hydralazine hydrochloride

Subject outcome measures, measured by Kansas City Cardiomyopathy Questionnaire (KCCQ)

In the mITT population, the KCCQ Overall Summary Score (OSS) improved over 6 months (52.8 ± 22.8 vs. 57.8 ± 24.2 points). Descriptive statistics for the KCCQ-OSS for the mITT population are shown in Table 12.

Table 12: Kansas City Cardiomyopathy Questionnaire OSS Score for the mITT Population

KCCQ Score	Time	Result	mITT (N=456)
Overall Summary Score	Screening	n	421
		missing (%)	35 (8.0%)
		mean (SD)	52.8 (22.8)
		median	52.6
		min	0.0
		max	100.0
	V3 - Month 1	n	407
		missing (%)	49 (11.0%)
		mean (SD)	55.8 (23.3)
		median	55.73
		min	2.6
		max	100.0
	V4 - Month 3	n	392
		missing (%)	64 (14.0%)
		mean (SD)	56.1 (24.6)
		median	56.68
		min	0.0
		max	100.0
	V5 - Month 6	n	379
		missing (%)	77 (17.0%)
		mean (SD)	57.8 (24.2)
median		58.33	
min		0.0	
max		100.0	
Screening vs. V5 - Month 6		p-value	<0.0001†
†Paired t-test			

Functional status improvement, as measured by six-minute walk test (6MWT)

In the mITT population, 6MWT distance increased, although not significantly, through 6 months (259.5 ± 121.1 vs. 283.2 ± 123.9 meters, $p=0.001$). Summary statistics for the mITT populations are shown in Table 13.

Table 13: 6-Minute Walk Test through 6 Months for the mITT Population

Category	Time	Result	mITT (N=456)
6MWT Total Distance Walked	Screening	n	436
		missing, (%)	20 (4.0%)
		mean (SD)	259.5 (121.1)
		median	267.74
		min	0.0
		max	780.0
	V5 - Month 6	n	347
		missing, (%)	109 (24.0%)
		mean (SD)	283.2 (123.9)
		median	290.0
		min	0.0
		max	640.0
Screening vs. V5 - Month 6		p-value	0.001†
†Paired t-test			

17.7.3 Subgroup Analyses

Main Analysis: Subgroups

Further analyses were undertaken to provide additional information of interest. The study was not specifically powered for the subgroups of the listed baseline characteristics. All p-values are for descriptive purposes only. The p-values are considered nominal.

The following baseline characteristics were evaluated for potential association with safety and effectiveness outcomes:

1. male vs. female
2. HFpEF vs. HFrfEF vs. HFmrEF
3. White vs. Non-White race
4. Hispanic vs. Non-Hispanic ethnicity
5. above median BMI vs. below median BMI
6. NT-proBNP > 1500 pg/mL vs NT-proBNP ≤ 1500 pg/mL
7. above median eGFR vs. below median eGFR
8. ischemic vs. non-ischemic HF
9. cardiac resynchronization therapy vs. no cardiac resynchronization therapy
10. enrollment type: all HFH vs. enrollment type: HFH criteria only vs. enrollment type: NT-proBNP criteria only vs. enrollment type: HFH & NT-proBNP criteria
11. pulmonary hypertension vs. no pulmonary hypertension
12. above target range vs. within/below target range
13. on SGLT2i at any time in 6-month follow-up vs. not on SGLT2i at any time in 6-month follow-up
14. on ARNI at any time in 6-month follow-up vs. not on ARNI at any time in 6-month follow-up
15. on MRA at any time in 6-month follow-up vs. not on MRA at any time in 6-month follow-up.

The 6-month incidence of HF related hospitalizations or all-cause mortality in all subgroups analyzed was significantly lower than the performance goal (0.43). The only subgroup comparisons that had significantly different event rates were those associated with pulmonary hypertension: pulmonary hypertension vs. no pulmonary hypertension (0.2349 vs. 0.0529, p<0.0001) and Above Target range vs. Below/Within Target Range (0.2540 vs. 0.0734, p=0.0001) and associated with high NT-proBNP: NT-proBNP > 1500 vs. NT-proBNP ≤ 1500 (0.2503 vs. 0.1053, p=0.0026). Results for each subgroup and subgroup comparison are shown in Table 14.

Table 14: Primary Efficacy Analysis: Subgroups

Subgroup	Event rate*	95% CI*
White (N=347)	0.1555	0.1114-0.2171
Non-White (N=109)	0.1704	0.1012-0.2866
Hispanic (N=20)	0.1036	0.0259-0.4142
Non-Hispanic (N=436)	0.1608	0.1208-0.2141
Below Median BMI (N=228)	0.1739	0.1159-0.2610
Above Median BMI (N=228)	0.1456	0.0985-0.2151
NT-proBNP > 1500 (N=148)	0.2503	0.1651-0.3796
NT-proBNP ≤ 1500 (N=298)	0.1053	0.0723-0.1532
Above Median eGFR (N=223)	0.1375	0.0897-0.2109
Below Median eGFR (N=231)	0.1795	0.1247-0.2630
Ischemic HF (N=143)	0.1857	0.1035-0.3333
Non-Ischemic HF (N=313)	0.1453	0.1085-0.1946
Cardiac Resynchronization Therapy (N=82)	0.1276	0.0593-0.2746
No Cardiac Resynchronization Therapy (N=374)	0.1658	0.1259-0.2242
Enrollment Type: All HFH (N=366)	0.1722	0.1271-0.2335
Enrollment Type: HFH criteria only (N=150)	0.103	0.0552-0.1920
Enrollment Type: NT-proBNP criteria only (N=89)	0.1047	0.0509-0.2151
Enrollment Type: HFH & NT-proBNP criteria (N=216)	0.2204	0.1562-0.3109
PH (baseline RHC mPAP > 20 mmHg) (N=264)	0.2349	0.1731-0.3188
No PH (baseline RHC mPAP ≤ 20 mmHg) (N=190)	0.0529	0.0284-0.0983
Above Target (seated mPAP > 20 mmHg) (N=206)†	0.254	0.1815-0.3555
Within Target (seated mPAP 5-20 mmHg) (N=247)†	0.0734	0.0462-0.1166
On SGLT2i at any time in 6-month follow-up (N=297)	0.1591	0.1149-0.2204
Not on SGLT2i at any time in 6-month follow-up (N=159)	0.1585	0.0919-0.2734
On ARNI at any time in 6-month follow-up (N=212)	0.16	0.1061-0.2415
Not on ARNI at any time in 6-month follow-up (N=224)	0.1579	0.1074-0.2322
On MRA at any time in 6-month follow-up (N=336)	0.1631	0.1187-0.2243
Not on MRA at any time in 6-month follow-up (N=120)	0.1475	0.0808-0.2691
*Event rates with 95% confidence intervals were calculated using a negative binomial model		
† From baseline defined as the first trend seated mPAP transmission		
SGLT2i = Sodium-Glucose Transport Protein 2 Inhibitors; ARNI = Angio-tensin Receptor/Nepriylsin Inhibitor; MRA = Mineralocorticoid Receptor Antagonist; BMI = Body Mass Index; HFH = Heart Failure Hospitalization; NT-proBNP = N-terminal Prohormone of Brain Natriuretic Peptide; HF = Heart Failure; PH = Pulmonary Hypertension; RHC = Right Heart Catheterization; mPAP = Mean Pulmonary Artery Pressure		

17.7.4 Pediatric Extrapolation

In this premarket application, existing clinical data was not leveraged to support approval of a pediatric patient population.

17.8 Conclusions

17.8.1 Effectiveness Conclusions

The benefits of the device are based on data collected in a single arm clinical study conducted to support PMA approval as described above.

The primary efficacy endpoint of the 6-month incidence of HF related hospitalizations or all-cause mortality in the modified Intent-to-Treat (mITT) population was met. For study success, the upper confidence bound of the observed event rate in the mITT population was required to be less than the performance goal (PG) which was 0.43 events per patient 6-month, or equivalently, that the corresponding p-value from the hypothesis test (6-month primary event rate < PG) was less than 0.025. Furthermore, the observed rate must be less than 0.37. Given that the upper confidence bound of the observed event rate was less than PG (0.2106 vs 0.43), the observed rate was significantly lower than PG (0.1589 vs 0.43; p<0.0001), and the observed rate was less than 0.37, all criteria for the primary efficacy endpoint were satisfied. The primary efficacy endpoint was tested in a number of subpopulations as prespecified by the PROACTIVE-HF protocol. These analyses were separate from the primary efficacy outcomes and were not endpoint contributing and so the findings here are hypothesis generating. All subgroups of the mITT population analyzed (Male, Female, HFpEF, HFrEF, HFmrEF) met the criteria for primary endpoint success with low rates of HF hospitalizations and mortality across all subgroups.

However, the population initially enrolled into PROACTIVE-HF as the control group in the randomized arm (Cohort #1) did not meet the criteria for efficacy endpoint success although the 6-month incidence of HFH or all-cause mortality was low (0.31 [95% CI: 0.13, 0.72]). Furthermore, the 6-month incidence of HF related hospitalizations or all-cause mortality was higher in Cohort #1 compared to the mITT population (Cohort #2 and Cohort #3) (0.3106 vs. 0.1589, $p=0.0859$; $\alpha=0.15$) but lower than historical control groups. There was no difference between Cohort #1 and Cohort #2 (0.3106 vs. 0.1557, $p=0.2378$) event rates. There was an absence of difference between Cohort #2 and Cohort #3 (0.1557 vs. 0.1595, $p=0.8979$). Recall, the study was not prospectively powered for these analyses, p -values are nominal, and the results are hypothesis generating. However, the differences between Cohort #1 and both Cohort #2 and Cohort #3 may be attributed to the fact that the Cohort #1 population did not have access to PAP (neither did their clinicians) for a median of 170 days in the 6 month follow-up but had access to vital signs for the entire duration of follow-up. Once PROACTIVE-HF was changed to a single arm trial, subjects and their clinicians in Cohort #1 were unblinded to PAP. In the 6 months following unblinding, the rate of HF hospitalization or all-cause mortality was 0.13 events per patient 6-month and at 12 months post-unblinding, the rate was 0.34 events per patient 12-month.

The primary 6-month incidence of HF related hospitalizations requiring one calendar day change or all-cause mortality was primarily made up of HF related hospitalizations, which occurred with an incidence of 0.1334 [95% CI: 0.0989, 0.1798] events per patient 6-months. The incidence of all-cause mortality was 0.0221 [95% CI: 0.0119, 0.0411] events per patient 6-month. These incidence rates were composed of 60 HF related hospitalizations and 10 all-cause deaths. These results compare favorably with the first randomized trial in PAP-guided HF management (CHAMPION), which reported 6-month incidences of HF related hospitalizations or all-cause mortality of 0.37. More contemporary trials only report 12-month incidences but estimating the 6-month rates via an exponential distribution result in 6-month incidences of HF related hospitalizations or all-cause mortality of 0.31 in GUIDE-HF NYHA III and 0.31 in MONITOR-HF. While PROACTIVE-HF did not include emergency department / hospital outpatient IV diuretic visits in the primary efficacy endpoint, these data are reported in the secondary outcomes. Including emergency department / hospital outpatient IV diuretic visits along with HF related hospitalizations and all-cause mortality results in an event rate of 0.1925 [95% CI: 0.156, 0.2375]. Of the 10 all-cause deaths, six were cardiac related resulting in a 6-month incidence of cardiac mortality of 0.0133 [95% CI: 0.006, 0.0295].

In the mITT population, the average seated trend mPAP increased over 6 months (20.2 ± 10.3 vs. 21.4 ± 9.3 mmHg, paired t -test $p=0.0016$). However, the target range for seated mPAP was 5-20 mmHg and, for those subjects who were above target range at baseline (i.e. congested), there was a significant decrease in seated mPAP over 6 months (29.2 ± 7.7 vs. 26.8 ± 9.2 mmHg, paired t -test $p=0.0006$). For those subjects below / within target range at baseline (≤ 20 mmHg), there was significant increase in seated mPAP over 6 months (12.8 ± 4.9 vs. 17.0 ± 6.8 mmHg, paired t -test $p<0.0001$). It should be noted that, on average, these patients were still in target range at 6 months. The Cordella System is the first PAP-guided HF management system to incorporate seated PAP readings for HF management. As subjects spend most of their waking hours in an upright position, seated measurements may be more relevant for monitoring in ambulatory HF subjects. When subjects move from the supine to seated position, volume shifts may occur leading to venous pooling and seated PAP may be more representative of a subject's volume status under gravitational loading. The Cordella System is also the first PAP-guided HF management system to incorporate daily vital signs with seated PAP readings for HF management. For systolic blood pressure, both in-office (121.8 ± 19.1 vs. 115.9 ± 18.9 , paired t -test p -value <0.0001) and home (118.4 ± 20.0 vs. 115.6 vs. 18.1 mmHg, paired t -test p -value 0.0056) readings were significantly lower at 6 months.

In the mITT population, the KCCQ Overall Summary Score improved over 6 months (52.8 ± 22.8 vs. 57.8 ± 24.2 points). Importantly, a change in 5 points is considered to be a small but clinically important change.¹⁵ Functional capacity, as measured by 6MWT improved in the mITT population (259.5 ± 121.1 vs. 283.2 ± 123.9 m). While NT-proBNP did not decrease significantly ($p=0.06$), the trend was favorable.

Much of the success of PAP-guided HF management relies on subjects sending in their data and clinicians responding in a timely and appropriate manner to those data. In PROACTIVE-HF, patient compliance was defined as transmitting at least 5 days of Cordella clinical data per week (did not need to be consecutive days). Subject compliance was very good with an average of 88% compliance over 6 months. Put another way, subjects submitted, on average, 6.2 days every week through 6 months. For the sites, compliance was defined as A) acknowledgements of all subjects' vital signs at least two times a week with a maximum of 4 days between data reviews and B) documentation of patient treatment decisions within the PMP system for each notification generated by the system. Here again, compliance was very good with an average of 93% acknowledging of subjects' PAP and vital signs within 4 days of transmission with an average of 2.2 days between transmission and acknowledgment. Furthermore, 93% of the notifications generated by the Cordella System had the related patient treatment decision entered into the system.

17.8.2 Safety Conclusions

The risks of the device are based on data collected in a clinical study conducted to support PMA approval as described above.

The study's first primary safety endpoint was the freedom from a Device/System-Related Complication (DSRC) through 6 months. Four adjudicated DSRC events were observed in the ITT population during the follow-up and the probability of being free from a DSRC at 6 months post-implant procedure was 99.2%.

None of the DSRCs resulted in permanent subject impairment or death and all subjects recovered without sequelae. The outcomes for DSRCs support an acceptable safety profile for Cordella PA Sensor implantation procedures and follow up, suggesting that even when DSRCs occurs, they can be managed effectively without long-term negative impacts on the patient. The first primary safety endpoint was met. However, with an event rate of 3.0% for all-cause hemoptysis, the event rate of this safety endpoint in the early experience with this new device is numerically higher than prior studies completed to date with similar PAP-measuring devices, such as in CHAMPION (0.2%), GUIDE-HF (0.3%) and MONITOR-HF (2.3%). The study's second primary safety endpoint was the freedom from Pressure Sensor Failure through 6 months. One event of Pressure Sensor Failure was reported and adjudicated and the probability of being free from a Pressure Sensor Failure event at 6 months post-implant procedure was 99.8%. Again, this is similar to what has been reported for the

currently approved device. The second primary safety endpoint was met. Throughout the study thus far, there are no other reports on implanted PA sensors failing to provide readings indicating very good sensor stability and system performance.

There were comparable incidences of HF adverse events in the different subject populations, including hospitalizations, emergency department visits, and outpatient office or practice visits. Similar incidences of acute kidney injury and renal dysfunction were observed, along with vascular access site complications and vessel trauma. Peri-procedural hemoptysis was noted in 15 cases and all subjects with hemoptysis recovered.

In ITT and Cohort #1 populations, CEC adjudicated prespecified related Non-DSRC AEs/SAEs summed to seventy total events with (possible) relationship to procedure and/or study device. Ten of the (possibly) procedure related events were also related to study device and two events were related to study device only.

Fifty-four (54) of related events occurred in ITT population, thirty-eight (38) in prespecified SAE categories and sixteen (16) in category "Other". The most common were Hemoptysis (n=15, 3%; number of events =15) and Vascular Access Site Complications (n =12, 2.4%; number of events =13). Further related events were Conduction Disturbances and Arrhythmias (n =4, 0.8%; number of events =4), Bleeding (n =3, 0.6%; number of events =3), Heart Failure (n =2, 0.4%; number of events =2) and Pulmonary Embolism (n =1, 0.2%; number of events =1). In Cohort #1, a total of nine (serious) adverse events related to the procedure and/or study device were adjudicated. These included two instances of bleeding, two events of conduction disturbances and arrhythmias, one of each of vascular access site complication, and vessel trauma. Three procedure related category "Other" events were adjudicated. None of the AEs or SAEs related to the procedure or study device resulted in permanent impairment or death of any subject. With the exception of two instances, all subjects recovered without any lasting effects. One event of "Recovery with Sequelae" pertains to a device explant followed by the subject's full recovery. The second event of "Recovery with Sequelae" was succeeded by an event from which the subject has fully recovered. All subjects who experienced related events have not experienced any further events associated with the Cordella PA Sensor System during the study follow-up.

Observed hemoptysis events were mild or moderate, with most requiring no treatment beyond observation or medication. Interventions were limited to imaging during the RHC, chest X-ray, or CT Angiography. In two cases, intubation was necessary for airway protection, but both instances resulted in patient extubation and patient discharge. However, the occurrence of all-cause hemoptysis was numerically higher (3.0%) than prior studies completed to date with similar PAP-measuring devices, such as in CHAMPION (0.2%), GUIDE-HF (0.3%) and MONITOR-HF (2.3%). Based on internal clinical evaluation and event adjudication during the trial, IFU and physician training documents were updated to address the risks, lowering the Activation Clotting Time (ACT) requirement for the procedure and adding cautionary statements regarding guidewire insertion, all with the objective to decrease the residual risk of hemoptysis.

17.8.3 Overall Conclusions

The data in this application support the reasonable assurance of safety and effectiveness of this device when used in accordance with the indications for use. The primary and secondary safety and efficacy endpoints of PROACTIVE-HF were met. The safety profile showed 99.2% freedom from DSRC and 99.8% freedom from pressure sensor failure, with a 3.0% rate of all cause hemoptysis which was numerically higher than prior studies completed to date with similar PAP-measuring devices. In terms of effectiveness, the 6-month incidence of heart failure hospitalization and mortality were low across all populations analyzed. The incidence rate of 0.1589 [95% CI: 0.1200, 0.2106] events per patient 6-month met all criteria for primary endpoint success. While the PROACTIVE-HF aimed to enroll NYHA class III HF patients, the final event rate for the primary effectiveness endpoint (0.1589) was numerically much lower than the average event rate derived from published results from clinically relevant, contemporary studies of NYHA class III HF subjects (as evidenced by an historical performance goal originally set at 0.43). While supportive of the overall benefit of the device, the benefit profile was not compared against concurrent standard of care subjects which should be taken into account when considering this device for a patient until additional data is available.

There was an improvement in quality of life by five points and 6MWT through 6 months. There was high compliance in both subject transmission of daily data and clinician acknowledgement of those transmissions. Of note, these secondary analyses are purely exploratory, not powered and not adjusted for multiple comparisons.

18. Contact Us

The user should contact Competent Authority and Endotronix Customer Service to report any serious incident that has occurred in relation to the medical device.

For technical assistance setting up or using the Delivery System, Reader and/or Dock, or CalEQ, contact Endotronix Customer Service.

Questions or concerns regarding unexpected operation or events, serious incidents, and general inquiries can be directed to the contact information below:

Endotronix Customer Service

Endotronix, Inc.
1415 West Diehl Road
Suite #500W
Naperville, IL 60563
U.S.A

+1 888 512 5595 (US)

1800 814 282 (IE)

0800 000 9241 (DE)

+32 800 82 244 (BE)

support@endotronix.com

Appendices

Appendix A: Electromagnetic Compatibility

Guidance and Manufacturer’s Declaration – Electromagnetic Emissions

The Reader and Docking Station are devices that comply with IEC 60601-1-2 Ed. 4.1. CalEQ is a device that complies with IEC 60601-1-2 Ed. 4.0. The Reader and Docking Station and CalEQ are intended for use in the electromagnetic environment specified below:

Emissions Test	Compliance	Electromagnetic Environment - Guidance
Conducted Emissions CISPR 11	Reader: Class B, Group 1 CalEQ: Class A, Group 1	The Reader must emit electromagnetic energy in order to perform its intended function. Nearby electronic equipment may be affected. The Reader is suitable for use in professional healthcare facility and home healthcare environments. The Calibration Equipment is suitable for use in professional healthcare facility.
Radiated Emissions CISPR 11	Reader: Class B, Group 1 CalEQ: Class A, Group 1	
Harmonic Current Emissions IEC 61000-3-2	Reader: Class A CalEQ: Class A	
Voltage changes, Fluctuations/ Flicker Emissions IEC 61000-3-3	Reader: Compliant CalEQ: Compliant	

The operator of the Reader and Docking Station and CalEQ should assure that it is used in such an environment.

NOTE: The EMISSIONS characteristics of CalEQ make it suitable for use in industrial areas and hospitals (CISPR 11 class A). If it is used in a residential environment (for which CISPR 11 class B is normally required) this equipment might not offer adequate protection to radio-frequency communication services. The user might need to take mitigation measures, such as relocating or re-orienting the equipment

Guidance and Manufacturer’s Declaration – Electromagnetic Immunity

The Reader and Docking Station are devices that comply with IEC 60601-1-2 Ed. 4.1. CalEQ is a device that complies with IEC 60601-1-2 Ed. 4.0.

The Reader and Docking Station are intended for use in the electromagnetic environment specified below:

Immunity Test	Test Level	Compliance	Electromagnetic Environment - Guidance
Electrostatic Discharge Immunity IEC 61000-4-2	±8kV contact ±2kV, ±4kV, ±8kV, ±15kV air	±8kV contact ±2kV, ±4kV, ±8kV, ±15kV air	Floors should be wood, concrete or ceramic tile. If floors are covered with synthetic material, the relative humidity should be at least 30%.
Electrical Fast Transient/Burst Immunity IEC 61000-4-4	±2 kV for power supply lines	±2 kV for power supply lines	
Surge IEC 61000-4-5	±1 kV line to line	±1 kV line to line	Mains power quality should be that of a typical professional healthcare facility or home healthcare environments.
	±0.5 kV line to line	±0.5 kV line to line	
Voltage dips, short interruptions and voltage variations on power supply input lines IEC 61000-4-11	0% UT (100% dip in UT) for 0.5 cycle	0% UT (100% dip in UT) for 0.5 cycle	
	0% UT (100% dip in UT) for 1 cycle	0% UT (100% dip in UT) for 1 cycle	
	70% UT (30% dip in UT) for 25 cycles(50Hz) and 30 cycles(60Hz)	70% UT (30% dip in UT) for 25 cycles(50Hz) and 30 cycles(60Hz)	
	0% UT (100% interruption in UT) for 250 cycles(50Hz) and 300 cycles(60Hz)	0% UT (100% interruption in UT) for 250 cycles(50Hz) and 300 cycles(60Hz)	

Power Frequency Magnetic Field IEC 61000-4-8	30A/m 50Hz and 60Hz	30A/m 50Hz and 60Hz	Power frequency magnetic fields should be at levels characteristic of a typical professional healthcare facility or home healthcare environments.
Radiated RF Immunity IEC 61000-4-3	10V/m 80MHz-2.7GHz 80% AM at 1kHz	10V/m	Portable and mobile RF communication equipment should be no closer to any part of the system, including cables, than the recommended separation distance calculated from the equation applicable to the frequency of the transmitter.
Conducted RF Immunity IEC 61000-4-6	3 Vrms Outside the ISM Bands 6 Vrms In the ISM and amateur radio bands 150kHz to 80MHz	3 Vrms Outside the ISM Bands 6 Vrms In the ISM and amateur radio bands	Refer to the Recommended Separation Distances table for guidance on required separation distances based on the frequency of the transmitter. Interference may occur in the vicinity of equipment marked with the following symbol: 
Electromagnetic compatibility (EMC) IEC 61000-4-39	8A/m at 30kHz	8A/m at 30kHz	
	65A/m at 134.2kHz	65A/m at 134.2kHz	
	7.5A/m at 13.56MHz	7.5A/m at 13.56MHz	
NOTE: UT is the a.c. mains voltage prior to application of the test level.			

CalEQ is intended for use in the electromagnetic environment specified below:

Immunity Test	Test Level	Compliance	Electromagnetic Environment - Guidance
Electrostatic Discharge Immunity IEC 61000-4-2	±8kV contact ±2kV, ±4kV, ±8kV, ±15kV air	±8kV contact ±2kV, ±4kV, ±8kV, ±15kV air	Floors should be wood, concrete or ceramic tile. If floors are covered with synthetic material, the relative humidity should be at least 30%.
Electrical Fast Transient/Burst Immunity IEC 61000-4-4	±1 kV for signal leads ±2 kV for power supply lines	±1 kV for signal leads ±2 kV for power supply lines	Mains power quality should be that of a typical professional healthcare facility environments.
Surge IEC 61000-4-5	±1 kV line to line ±2 kV line to ground	±1 kV line to line ±2kV line to ground	
Power Frequency Magnetic Field IEC 61000-4-8	30A/m 50Hz	30A/m 50Hz	Power frequency magnetic fields should be at levels characteristic of a typical professional healthcare facility environments.
Radiated RF Immunity IEC 61000-4-3	3V/m 80MHz-2.7GHz 80% AM at 1kHz	3V/m	Portable and mobile RF communication equipment should be no closer than 20cm to any part of the system, including cables specified by Endotronix.
Conducted RF Immunity IEC 61000-4-6	3 Vrms Outside the ISM Bands 6 Vrms In the ISM and amateur radio bands 150kHz to 80MHz	3 Vrms Outside the ISM Bands 6 Vrms In the ISM and amateur radio bands	Interference may occur in the vicinity of equipment marked with the following symbol: 
NOTE: UT is the a.c. mains voltage prior to application of the test level.			
NOTE 1: These guidelines may not apply in all situations. Electromagnetic propagation is affected by absorption and reflection from structures, objects and people.			

Recommended Separation Distances Between Portable and Mobile RF Communications Equipment and the Reader

The Reader is intended for use in an electromagnetic environment in which radiated RF disturbances are controlled. The user of the Reader can help prevent electromagnetic interference by maintaining a minimum distance between portable and mobile RF communications equipment (transmitters) and the Reader as recommended below, according to the maximum output power of the communications equipment.

Rated Maximum Output Power of Transmitter (W)	Separation Distance According to Frequency of Transmitter (M)			
	174 MHz to 216 MHz $d = 1.2\sqrt{P}$	335 MHz to 450 MHz $d = 2\sqrt{P}$	809 MHz to 849 MHz $d = 0.3\sqrt{P}$	2.35 GHz to 2.65 GHz $d = 3.8\sqrt{P}$
1	1.20	2.00	0.30	1.20
10	3.79	6.32	0.95	3.79
100	12.00	20.00	3.00	12.00

For transmitters rated at a maximum output power not listed above, the recommended separation distance d in meters (m) can be estimated using the equation applicable to the frequency of the transmitter, where P is the maximum output power rating of the transmitter in watts (W) according to the transmitter manufacturer.

NOTE 1: For frequencies which may be described by two equations in the table above, the larger separation distance applies.

NOTE 2: These guidelines may not apply in all situations. Electromagnetic propagation is affected by absorption and reflection from structures, objects and people.

Reader Frequency Band

The Reader receives RF electromagnetic energy and includes RF transmitters that perform within the frequency range of 12.88MHz to 14.12MHz.

The Reader includes RF transmitters that perform at center bands (13.09MHz, 13.34MHz, 13.62MHz, and 13.90MHz).

BT Transceiver frequency

BT Smart Ready Module - FCC ID QOQBT121
Operating Frequency Range: 2402MHz – 2480MHz

Intel WiFi/Bluetooth Module FCC ID PD97265NG
Operating Frequency Range: 5.15GHz - 5.85GHz (dependent on country); 2.400 - 2.4835GHz (dependent on country).

FCC Statement

The Reader is approved for wireless transmission under FCC ID 2AR87ETXCPAS01. It has been tested and found to comply with the limits for a Class B digital device, pursuant to part 15 of the FCC Rules. These limits are designed to provide reasonable protection against harmful interference in a residential installation. This equipment generates, uses and can radiate radio frequency energy and, if not used in accordance with the instructions, may cause harmful interference to radio communications. However, there is no guarantee that interference will not occur in a particular installation. If this equipment does cause harmful interference to radio or television reception, which can be determined by turning the equipment off and on, the user is encouraged to try to correct the interference by one or more of the following measures:

- Reorient or relocate the receiving antenna
- Increase the separation between the equipment and receiver.
- Connect the equipment into an outlet on a circuit different from that to which the receiver is connected.
- Consult Customer Service.

This device complies with part 15 of the FCC Rules. Operation is subject to the following two conditions: (1) This device may not cause harmful interference, and (2) this device must accept any interference received, including interference that may cause undesired operation.

RF Exposure Compliance Information

This device meets the U.S. FCC's requirements for exposure to radio waves and is designed and manufactured not to exceed the emission limits for exposure to radio frequency (RF) energy.

Appendix B: Equipment Specifications

Cordella™ PA Sensor System

Manufacturer: Endotronix

Method of measurement: Wireless interrogation of implanted Cordella Sensor

Pulmonary artery pulse pressure maximum range:

40-100 mmHg

Pulmonary artery pressure range at sea level: 0-100 mmHg

System Accuracy (short-term under typical environmental conditions): +/- 2 mmHg at baseline and +/- 3% across the pressure range compared to a reference pressure measurement for a pressure range of 600-860mmHg (absolute).

Note: Accuracy of the Cordella PA Sensor System is affected by a change in body temperature, drift over time, positional variation of the Reader relative to the Sensor, and changes in ambient temperature and humidity. Error after combining all sources of variation is specified below.

Worst Case System Error: System Root Sum Square (RSS) error after combining all sources of variation must remain within +/- 7.8 mmHg over 10 years.

Patient safety/use: Typical reading time is 30 seconds.

Calibration: At implant and recalibration, approximately every 3-years, or when deemed necessary by a medical professional

myCordella™ Handheld Patient Reader

Manufacturer: Endotronix

Expected service life: Four years

Safety standards: Meets all relevant parts of IEC 60601-1 Ed. 3.2 and 60601-1-11 Ed. 2.1

Essential Performance: Error is less than 3 mmHg

EMC standards: Meets all relevant parts of IEC 60601-1-2 Ed. 4.1

Operating frequency: 12.88-14.12 MHz, 2.45 GHz

Physical

Approximate dimensions

- Width: 6.44 in / 16.35 cm
- Height: 2.0 in / 5.1 cm
- Depth: 5.63 in / 14.3 cm
- Weight: 1.2 lbs. / 0.54 kg

Power

Input of 4.2V/16.8V === 667mA/142mA

Environment

The Reader may not meet its performance specifications if stored or used outside the environmental ranges listed below.

Temperature

- Operation: 5 – 35 °C (41 – 95 °F)
- Transport: -10 – 55 °C (14 – 131 °F)
- Storage: -10 – 55 °C (14 – 131 °F)

Relative humidity

- Operation: 6 – 93% (non-condensing)
- Transport: 6 – 93% (non-condensing)
- Storage: 6 – 93% (non-condensing)

Atmospheric Pressure

- Operation: 800 – 1066 hPa

myCordella™ Docking Station

Manufacturer: Endotronix

Expected service life: Four years

Physical

Approximate dimensions

- Width: 5.5 in / 14.0 cm
- Height: 2.5 in / 6.4 cm
- Depth: 5.5 in / 14.0 cm
- Weight: 0.4 lbs. / 181.4 g

Environment

The Docking Station may not meet its performance specifications if stored or used outside the environmental ranges listed below.

Temperature

- Operation: 5 – 35 °C (41 – 95 °F)
- Transport: -25 – 70 °C (-13 – 158 °F)
- Storage: -25 – 70 °C (-13 – 158 °F)

Relative humidity

- Operation: 6 – 93% (non-condensing)
- Transport: 0 – 90% (non-condensing)
- Storage: 0 – 90% (non-condensing)



Atmospheric Pressure

- Operation: 800 – 1066 hPa

Power Cord

Cord length: ~ 5 feet / 1.5 m

AC Power: Wall mount style power supply

- Input of 100-240V , 50-60 Hz
- Output of 5V  @ 3A

Manufacturer: SL Power Electronics

Part No: ME20A0503B01

Docking Station

- Input: +5V  3.0 A

Output: 4.2V/16.8V, 667mA/142mA

Calibration Equipment

Manufacturer: Endotronix

Expected service life: Five years

Mechanical Characteristics

Approximate dimensions

- Width: 27 in / 69 cm
- Adjustable Height: 55 in – 66 in / 140 cm – 168 cm
- Depth: 27 in / 69 cm
- Total Weight of Fully Loaded Equipment: 82 lbs / 37 kg
- Maximum Allowed Basket Load: 11 lbs/5 kg
- Display: 21.5" LCD, 1920 x 1080 (16:9)

Environment

The CalEQ may not meet its performance specifications if stored or used outside the temperature and humidity ranges listed below.

Temperature

- Operation: 5 – 35 °C (59 – 86 °F)
- Transport: -20 – 45C °C (-4 – 113 °F)
- Storage: 0 – 25 °C (32 – 77 °F)

Relative humidity

- Operation: 10 – 90% (non-condensing)
- Transport: 10 – 90% (non-condensing)
- Storage: 10 – 90% (non-condensing)

Classification:

- Class I Equipment
- IP Rating
 - Computer Monitor: IP65 Front Panel, IPX1 Back Cover
 - Barcode Scanner: IP42
 - NI 9215 DAQ: IP40
 - Docking Station: IP21
- Continuous Use









Safety standards: Meets all relevant parts of IEC 60601-1 Ed. 3.1

EMC standards: Meets all relevant parts of IEC 60601-1-2 Ed. 4.0

Essential Performance: Reference pressure error is less than 4 mmHg









Electrical Characteristics









Power









- Computer Monitor
 - System Input: 12 – 48V 
 - AC Adapter
 - Input: 100 – 240V  , 50/60 Hz, 2.0 – 1.0A
 - Output: 19V  6.31A, 120W MAX
 - Cord Length: approx. 6 feet (2m)
 - Total Battery Capacity: 4700mAh
 - Battery Life (based on normal usage and environmental conditions): 3 hours
 - Charging Time (based on normal environmental conditions): 6.5 hours
- Multiple Socket Outlet (MSO)
 - REF: 100622-00
 - Input: 120V  , 60Hz, 12A
 - Output: 120V  , 60Hz, 12A
 - Cord Length: approx. 15 feet
 - REF: 100622-01
 - Input: 230V  , 50Hz, 13A
 - Output: 230V  , 50Hz, 13A
 - Cord Length: approx. 3m
 - REF: 100622-02, 100622-04
 - Input: 230V  , 50Hz, 16A
 - Output: 230V  , 50Hz, 16A
 - Cord Length: approx. 3m





Definition of Symbols









The following symbols are used on the labels of the Cordella Pulmonary Artery Sensor System:

Symbol	Standard	Clause Number	Explanatory Text
Rx Only	N/A	N/A	Caution: Federal law restricts this device to sale by or on the order of a physician.
	ISO 15233-1 Medical devices – Symbols to be used with medical device labels, labelling and information to be supplied.	5.7.10	Unique Device Identifier
	ISO 15233-1 Medical devices – Symbols to be used with medical device labels, labelling and information to be supplied.	5.7.7	Medical Device
	ISO 15233-1 Medical devices – Symbols to be used with medical device labels, labelling and information to be supplied.	5.4.12	Single Patient Multiple Use
	ISO 15233-1 Medical devices – Symbols to be used with medical device labels, labelling and information to be supplied.	5.2.13	Single Sterile Barrier System with protective packaging inside
	ISO 15233-1 Medical devices – Symbols to be used with medical device labels, labelling and information to be supplied.	5.1.6	Manufacturer's catalogue or part number so that the medical device can be identified.
	ISO 15233-1 Medical devices – Symbols to be used with medical device labels, labelling and information to be supplied.	5.1.5	Manufacturer's batch code so that the batch or lot can be identified.
	ISO 15233-1 Medical devices – Symbols to be used with medical device labels, labelling and information to be supplied.	5.1.7	Manufacturer's serial number so that a specific medical device can be identified.
	ISO 15233-1 Medical devices – Symbols to be used with medical device labels, labelling and information to be supplied.	5.1.8	Importer

Symbol	Standard	Clause Number	Explanatory Text
	ISO 15233-1 Medical devices – Symbols to be used with medical device labels, labelling and information to be supplied.	5.1.2	Authorized representative in the European Community.
	IEC 60601-1 Medical electrical equipment – Part 1: General requirements for basic safety and essential performance.	Table D.2, Symbol 10	Need for the user to consult the instructions for use.
	ISO 15233-1 Medical devices – Symbols to be used with medical device labels, labelling and information to be supplied.	5.3.2	Medical device that needs protection from light sources or heat.
	ISO 15233-1 Medical devices – Symbols to be used with medical device labels, labelling and information to be supplied.	5.3.7	Temperature limits to which the medical device can be safely exposed.
	ISO 15233-1 Medical devices – Symbols to be used with medical device labels, labelling and information to be supplied.	5.3.8	Humidity limits to which the device can be safely exposed.
	ISO 15233-1 Medical devices – Symbols to be used with medical device labels, labelling and information to be supplied.	5.3.9	Atmospheric pressure limits to which the device can be safely exposed.
	ISO 15233-1 Medical devices – Symbols to be used with medical device labels, labelling and information to be supplied.	5.3.4	Device that needs to be protected from moisture.
	ISO 15233-1 Medical devices – Symbols to be used with medical device labels, labelling and information to be supplied.	5.3.1	Device that can be broken or damaged if not handled carefully.
	Federal Communications Commission	N/A	Federal Communication Commission Number.

Symbol	Standard	Clause Number	Explanatory Text
	ISO 15233-1 Medical devices – Symbols to be used with medical device labels, labelling and information to be supplied.	5.1.1	Device manufacturer.
	ISO 15233-1 Medical devices – Symbols to be used with medical device labels, labelling and information to be supplied.	5.1.3	Date when the device was manufactured.
	ISO 15233-1 Medical devices – Symbols to be used with medical device labels, labelling and information to be supplied.	5.1.4	Expiration date.
	IEC 60601-1 Medical electrical equipment – Part 1: General requirements for basic safety and essential performance.	Table D.1, Symbol 4	Device should be attached to direct current source.
	IEC 60601-1 Medical electrical equipment – Part 1: General requirements for basic safety and essential performance.	Table D.1, Symbol 8	Device should be attached to alternating current source.
	IEC 60417 Graphic symbols for use on electrical equipment	Table D.1, Symbol 9	Equipment meeting the safety requirements specified for Class II equipment according to IEC 61140.
	IEC 60601-1 Medical electrical equipment – Part 1: General requirements for basic safety and essential performance.	Table D.2, Symbol 20	Type BF applied part complying with IEC 60601-1.
	N/A	UN 3841	The myCordella Handheld Patient Reader and Calibration Equipment operate using lithium-ion batteries. Lithium-ion batteries should not be crushed or burned.

Symbol	Standard	Clause Number	Explanatory Text
IPN₁N₂	IEC 60601-1 Medical electrical equipment – Part 1: General requirements for basic safety and essential performance.	Table D.3, Code 2	Manufacturer-determined degree of particle and water ingress protection, where... N1 = degree of protection from particulates (scale of 0-6); and N2 = degree of protection from water (scale of 0-8)
IP21	IEC 60601-1 Medical electrical equipment – Part 1: General requirements for basic safety and essential performance.	Table D.3, Code 2	Protected against solid foreign objects of 12.5 mm and greater, and against the effects of dripping water.
IP22	IEC 60601-1 Medical electrical equipment – Part 1: General requirements for basic safety and essential performance.	Table D.3, Code 2	Protected against solid foreign objects of 12.5 mm and greater, and against the effects of dripping water when tilted at 15°.
IP42	IEC 60601-1 Medical electrical equipment – Part 1: General requirements for basic safety and essential performance.	Table D.3, Code 2	Protected against solid foreign objects of 1.0 mm or greater, and against the effects of dripping water when tilted at 15°.
IP65	IEC 60601-1 Medical electrical equipment – Part 1: General requirements for basic safety and essential performance.	Table D.3, Code 2	Protected against total dust ingress, and against the effect of low pressure water jets from any direction.
	ASTM F2503 Standard Practice for Marking Medical Devices and Other Items for Safety in the Magnetic Resonance Environment.	7.3.2	Device has been demonstrated to pose no known hazards in a specified MRI environment with specified conditions of use.
	ISO 15233-1 Medical devices – Symbols to be used with medical device labels, labelling and information to be supplied.	5.4.4	General warning.
	N/A	N/A	On/Standby button.
	IEC 60417 Graphic symbols for use on electrical equipment	7000-5140	IEC 60417-5140 - Equipment includes RF Transmitter.

Symbol	Standard	Clause Number	Explanatory Text
	EN 50419 Marking of Electrical and Electronic Equipment in accordance with Article 11(2) of Directive 2009/96/EC (WEEE)	N/A	Electronic equipment covered by the Directive 2002/96/EC on waste electrical and electronic equipment (WEEE). All electrical and electronic products, batteries, and accumulators must be taken to separate collection at the end of their working life. This requirement applies in the European Union. Do not dispose of these products as unsorted municipal waste.
	ISO 15233-1 Medical devices – Symbols to be used with medical device labels, labelling and information to be supplied.	5.4.2	Do not re-use.
	ISO 15233-1 Medical devices – Symbols to be used with medical device labels, labelling and information to be supplied.	5.2.3	Sterilized with ethylene oxide.
	IEC 60417 Graphic symbols for use on electrical equipment	7000-1321B	Mass.
	ISO 15233-1 Medical devices – Symbols to be used with medical device labels, labelling and information to be supplied.	5.2.6	Do not re-sterilize.
	ISO 15233-1 Medical devices – Symbols to be used with medical device labels, labelling and information to be supplied.	5.2.8	Do not use if package is damaged.
	ISO 15233-1 Medical devices – Symbols to be used with medical device labels, labelling and information to be supplied.	5.4.3	Refer to Instructions for Use
	ISO 15233-1 Medical devices – Symbols to be used with medical device labels, labelling and information to be supplied.	5.4.3	Refer to electronic Instructions for Use on this website.

Symbol	Standard	Clause Number	Explanatory Text
	ISO 15233-1 Medical devices – Symbols to be used with medical device labels, labelling and information to be supplied.	5.4.5, Reference Annex B for the general negation symbol	Not made with natural rubber latex

(page left blank intentionally)

Cordella, myCordella, and Endotronix are trademarks of Endotronix, Inc.

©2024 Endotronix, Inc. All rights reserved

Patents: www.endotronix.com/patents